

JC2000

MULTI AXIS CONTACTLESS JOYSTICK

The JC2000 contactless joystick controller is designed for precision fingertip control applications where safety and long trouble-free life are primary requirements. It is available in one, two or three axis configurations and can accommodate a choice of handles, including push-button switch versions. Two mounting flange options allow attachment above or below the panel. The JC2000's compact size, low operational force and high reliability are ideal for applications which include powered wheelchairs, robotics, CMM machines, medical and CCTV equipment, professional camera controls and remote controlled chest-packs.



PERFORMANCE MECHANICAL

XY axes

Lever operating force

breakout	N	1 or 3*
operating	N	2 or 4.5* (full deflection)
maximum allowable	N	300* (XY version) 195N* (XYZ version)
Lever action (options)		Self centering, aligned X and Y or non aligned
Lever gate profiles (options)		Single axis, round, square, diamond, cross or plus

Lever mechanical angle

single axis only	°	± 20 in forward/reverse directions
round gate	°	± 20
square and diamond gate	°	± 20 to corners (± 14 to flats)
cross and plus gate	°	± 20 at extent of travel

Expected life 15 million operations (5 million with heavy duty spring)

Weight g 90 without handle fitted
*Measured 40mm above upper flange face

Z axis (handle style E and HL only)

Handle rotational torque

breakout	Nm	0.04
operating	Nm	0.06
maximum allowable	Nm	1.0

Handle mechanical angle ° ± 20

Handle action Self centering

Expected life 5 million operations

ENVIRONMENTAL

Operating temperature °C -25 to +70

Storage temperature °C -40 to +70

Environmental protection above flange IP65 IEC 60529

EMC immunity level 60V/m, 25MHz to 1GHz, 1KHz 80% sine wave modulation, EN50082-2 (Sept 1995)

EMC emissions level Complies with EN50081-1 (1992), 30MHz to 1GHz

ESD immunity level EN50082-2 (1995) ± 8kV contact discharge; ± 15kV air discharge (10 discharges)

ELECTRICAL

Sensor type Hall effect

Resolution Infinite

Supply voltage range Vs Vdc 5 ± 0.5 regulated transient free

Over voltage (maximum) Vdc 15 continuous

Reverse polarity (maximum) Vdc 14.5

Output voltage span (options)	Gate option	Minimum	Nominal	Maximum
X, XY and XYZ** Code 25	Vdc 1, R, D, C, P	1.25 to 3.75	1.10 to 3.90	0.97 to 4.03
	Vdc S**	1.67 to 3.32	1.55 to 3.45	1.43 to 3.57
Code 30	Vdc 1, R, S, D, C, P	1.15 to 3.85	1.00 to 4.00	0.85 to 4.15
Code 40	Vdc 1, R, D, C, P	0.65 to 4.35	0.50 to 4.50	0.35 to 4.65
	Vdc S	1.10 to 3.90	0.80 to 4.20	0.50 to 4.50

** consult sales team for available options

Output impedance	Ω	100 each axis
Center reference output (no load)	%	49 - 51 of supply voltage V_s
Center reference impedance	$k\Omega$	1.1
Current consumption - max	mA	24
Return to center voltage-no load	mV	X and Y axis Within ± 60 of $V_s/2$ @ 20°C (± 73 over full temperature range)
		XY with gate S Within ± 113 of $V_s/2$ @ 20°C (± 126 over full temperature range)
		Z axis Within ± 100 of $V_s/2$ @ 20°C (± 113 over full temperature range)
Output ramp		XY axes The dual outputs of the XY axes can be independently selected to be rising together in the same direction (PP) or opposed (PN). See order code
		XYZ The three axis version can only provide a single output per axis

DIMENSIONS

Top flange option

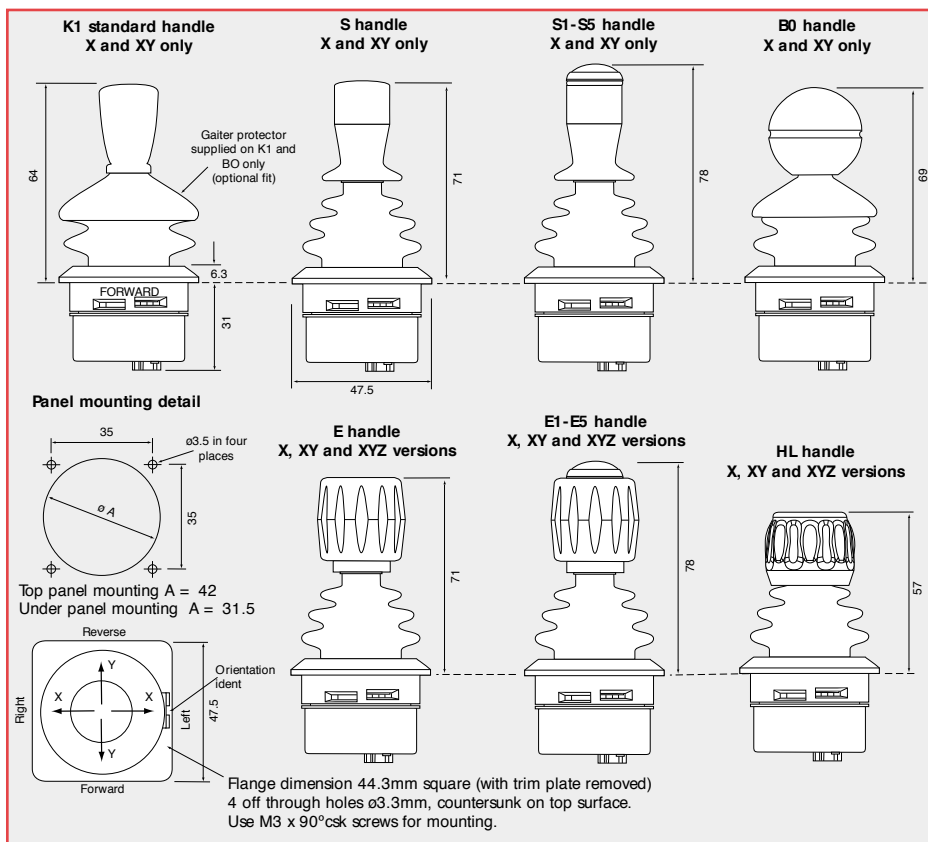

DIMENSIONS

Mid flange option
X and XY axes only

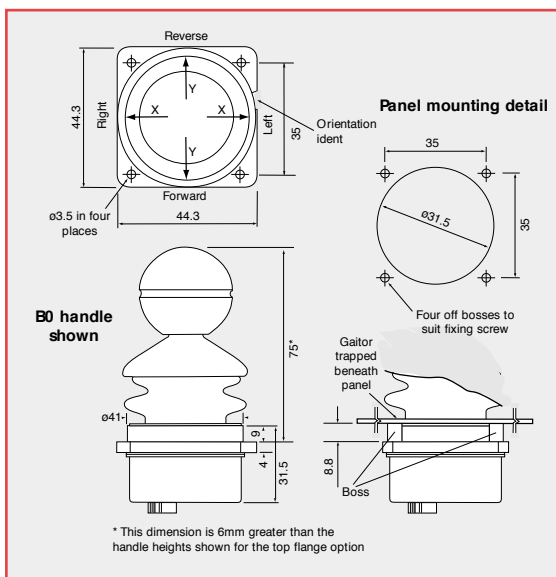

OUTPUT TRACKING

Output shown for same direction - PP or NN

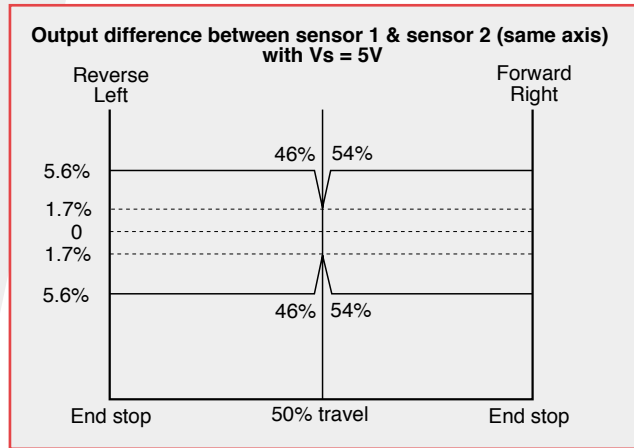

ELECTRICAL CONNECTIONS

Mating Connector

8 Pin FCI Minitek™ 89361-708 IDC Connector (order separately as P302137) or supplied with 0.5m ribbon cable fitted (order as P302138)

		Pin Number	Description
	1	1	XY Joystick
	3	2	Positive voltage supply
	5	3	Left/Right output 1
	7	4	Zero voltage supply
		5	Forward/Reverse output 1
		6	Forward/Reverse output 2
		7	Center tap
		8	Left/Right output 2
		8	Switch output (NC if no switch)
			Switch output (NC if no switch)

Switch is connected between pin 1 and 8

JC2000 MULTI AXIS CONTACTLESS JOYSTICK HOW TO SPECIFY

PERFORMANCE OPTIONS	FEATURE	CODE	FEATURE AVAILABILITY		
			X	XY	XYZ
MOUNTING FLANGE	Top flange	JC2000-T	✓	✓	✓
	Mid flange (not available with XYZ)	JC2000-M	✓	✓	
AXES	Single axis	X	✓		
	Dual axis	XY		✓	
	Three axis (only available with top flange)	XYZ			✓
OUTPUT RAMP	dual output - same ramp	PPOOO	✓		
	dual output - opposite ramp	PNOOO	✓		
	dual output - same ramp each axis	PPPPPO		✓	
	dual output - same ramp X, opposite ramp Y	PPNNO		✓	
	dual output - opposite ramp each axis	PNPNO		✓	
	single output - same ramp each axis	POPOP			✓
	single output - same ramp X and Z, opposite ramp Y	PONOP			✓
	single output - same ramp Y and Z, opposite ramp X	PONON			✓
	single output - opposite ramp each axis	NONON			✓
OUTPUT SPAN	1.1 to 3.9 Vdc nominal	25	✓	✓	✓
	1.0 to 4.0 Vdc nominal	30	✓	✓	✓*
	0.5 to 4.5 Vdc nominal	40	✓	✓	✓*
HANDLE STYLES See page 23	Standard tapered handle	K1	✓	✓	
	Ball handle	B0	✓	✓	
	Short ergonomic handle	HL	✓	✓	✓
	Ergonomic handle	E	✓	✓	✓
	Ergonomic with Black push button	E1	✓	✓	✓
	Ergonomic with Red push button	E2	✓	✓	✓
	Ergonomic with Green push button	E3	✓	✓	✓
	Ergonomic with Yellow push button	E4	✓	✓	✓
	Ergonomic with Blue push button	E5	✓	✓	✓
	Straight handle	S	✓	✓	
	Straight with Black push button	S1	✓	✓	
	Straight with Red push button	S2	✓	✓	
	Straight with Green push button	S3	✓	✓	
	Straight with Yellow push button	S4	✓	✓	
	Straight with Blue push button	S5	✓	✓	
GATE (lever movement limiter)	Single axis	1	✓		
	Round	R		✓	✓
	Square*	S		✓	✓
	Diamond	D		✓	✓
	Cross X	C		✓	✓
	Plus +	P		✓	✓
SEAT	Aligned with axis	P		✓	✓
	Non-aligned	N	✓	✓	✓
LEVER SPRING FORCE	Standard duty, 1N breakout, 2N full deflection	S	✓	✓	✓
	Heavy duty, 3N breakout, 4.5N full deflection	H	✓	✓	✓

EXAMPLE ORDER CODE JC2000-T-XY-PPPPO-40-E5-R-P-H

Two axis version with all outputs same sense, 40% output span, ergonomic handle style with Blue push button switch, round gate and aligned seat, with heavy spring.

*Consult the sales team for available output span options, when selecting XYZ with S gate option.

GENERAL NOTES ON FINGER OPERATED JOYSTICKS

MECHANICAL LOADS

Penny+ Giles joystick controllers are robust and designed to suit typical applications. System designers should ensure that the joystick is not positioned where it could be subjected to excessive loads greater than the maximum allowable load stated in the product specification.

MODIFICATION AND USAGE

Any modification of a joystick by the user is strongly discouraged and will invalidate the warranty and Penny+ Giles liability. The handles supplied with the finger operated controllers are intended for fingertip and not full hand operation. Handles **must not** be replaced with a taller handle otherwise the increased load applied to the joystick may result in permanent damage.

USER MAINTENANCE/ADJUSTMENT

All joysticks are supplied by Penny+ Giles fully adjusted and ready for installation. There are no user adjustable or maintainable parts within the joysticks. Any attempt to dismantle the joystick will invalidate the warranty and may leave the system into which the joystick is installed in a dangerous condition.

SAFETY

For a system to operate safely it must be able to differentiate between commanded and uncommanded inputs. System designers should take steps to detect and manage joystick and system failures that may give rise to an erroneous output. For safety critical functions we recommend that an independent momentary action 'system enable' switch is used. This switch can be incorporated into the joystick as a 'Person Present' switch or can be a separate foot or hand operated momentary switch. All functions controlled by the joystick should be disabled when this switch is released. The control system should look for the appropriate 'system enable' switch output before the joystick is displaced from the neutral position. Functions controlled by the joystick should not be enabled until this is the case.

JOYSTICK INTEGRITY CHECK ON POWER UP

On system power-up, the system should check that all joystick outputs are in neutral and safety critical functions controlled by the joystick should not be enabled until this is the case.

LIFE

Penny+ Giles joysticks are designed and tested to provide a working life that is acceptable for the majority of applications. System designers should be satisfied that the life stated in the joystick specification is sufficient for the intended application.

JC2000 INSTALLATION AND APPLICATION NOTES

SEALING THE JOYSTICK TO THE PANEL

See panel mounting detail on page 23 for recommended machining detail to accept the JC2000. Prior to installation check that the gate (lever movement limiter) positioned under the gaiter at the top of the joystick is correctly located and orientated.

The joystick is sealed above the mounting surface to prevent dust and water ingress to IP65 and is supplied with mounting hardware (sealing gasket and trim plate) suitable for mounting from above the panel face. The effectiveness of the seal is dependent on the mounting surface being sufficiently rigid to compress the sealing gasket. The finish of the mounting surface is critical to achieving an adequate seal and rough surface finishes, paint chips, deep scratches etc. should be avoided. The joystick should not be used if the flexible rubber gaiter becomes perforated.

Below the mounting surface the joystick should be allowed to breathe freely but be protected from excessive dust and direct water spray. Where the joystick is mounted in a control box, the box should be allowed to breathe at its lowest point. If the box is subjected to water spray it may be necessary to provide a waterproof breather at the lowest point.

It is possible to mount the JC2000 from under the panel surface by discarding the trim plate and sealing gasket and compressing the base of the flexible gaiter against the panel and mounting flange. This reduces the lever height above the panel, but increases the space required to accommodate the joystick body below the panel. See panel mounting detail on page 23 for dimensions.

DUAL OUTPUTS - X AND XY VERSIONS ONLY

Each JC2000 joystick axis is equipped with two outputs and it is recommended that both outputs are continuously compared to ensure that the difference does not exceed the maximum specified difference plus a suitable 'safety margin'. In addition, machine movement should not be enabled until both outputs from any one axis exceed the centre threshold voltage plus a suitable 'safety margin'. (e.g. 2 x joystick centre tolerance)

The outputs in normal use are within the maximum span limits shown on page 22. Any output significantly outside of this range must be regarded as erroneous and appropriate safe action taken. A high value pull-up or pull-down resistance should be added to the X and Y outputs such that in the unlikely event of a wire or connector failure the output will be pulled out of range.

DUAL OUTPUT SENSE (DIRECTION)

Dual outputs from any JC2000 joystick axis can be configured during manufacture in one of two possible ways. These are designated within the joystick specification as same-ramp (P) or opposite-ramp (N). The diagrams, below, show dual outputs; for single output or a Z axis either output 1 or 2 can be chosen.

The ramps at their lower end start at 25%, 20% or 10% of supply voltage and at their upper end finish at 75%, 80% or 90% of supply voltage, depending on output option.

In the same-ramp configuration the outputs of an axis can be directly compared to determine the serviceability of the joystick.

In the opposite-ramp configuration the sum of the outputs from any axis should within limits, equal the applied voltage.

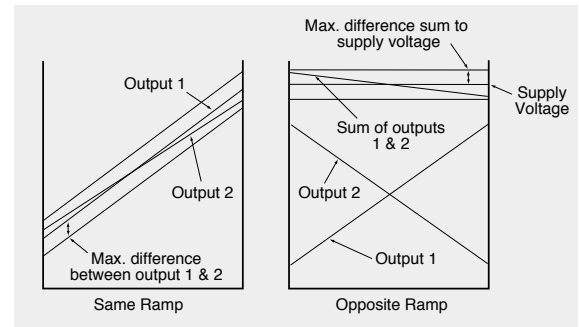

CENTER TAP

A center tapping is provided as a means of verifying the integrity of the supply voltage at the joystick. Clearly a high resistance or open circuit in either the +ve supply or 0V connections will affect the joystick outputs. The normal output at the center tap connection is 49% to 51% of the supply voltage. A center tap output outside this range indicates a fault in the supply to the joystick.

SINGLE OUTPUTS - XYZ ONLY

Where a JC2000 joystick incorporating only a single sensor per axis is used to control safety critical functions an independent momentary action system enable switch must be provided.

OUTPUT IMPEDANCE

The outputs at the center position and the end of travel are specified with an infinite load impedance or zero current. The effect of adding a finite load impedance will be to source or sink current through the joystick output impedance. The voltage dropped through the joystick output impedance must be taken into account when the system threshold voltages are being defined. The impedance of the JC2000 outputs are specified on page 23.

OUTPUT NOISE

The JC2000 incorporates Hall effect sensors to detect the position of each of the joystick axes. A side effect of the use of these sensors is electrical noise superimposed on the output, typically of the order of 20mV peak to peak. This noise can be simply filtered out by the user.

MAGNETIC IMMUNITY

Magnetic screening minimises the sensitivity to external magnetic fields. However the use of the joystick in close proximity to sources of high magnetic fields is not recommended.

APPLIED VOLTAGES

The JC2000 is designed to operate from a regulated 5Vdc \pm 0.5V supply, free from voltage transients. Under no circumstances should voltages above 5.5V be applied to the joystick. The outputs from the JC2000 are ratiometric and are dependent on the input voltage.