

JC025 AND JC030

SINGLE AXIS ROCKER

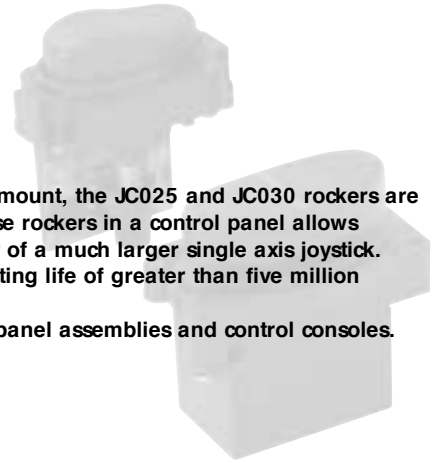

Developed for applications where compact size and minimal above panel height is paramount, the JC025 and JC030 rockers are very low profile whilst still providing precise fingertip control in one axis. The use of these rockers in a control panel allows designers to develop very low profile assemblies whilst still maintaining the functionality of a much larger single axis joystick. These rockers have been designed for maintenance-free operation throughout an operating life of greater than five million operations.

Typical applications include remote control chest packs, pendant controllers, low profile panel assemblies and control consoles.

PERFORMANCE MECHANICAL

Breakout force	N	5*	
Operating force	N	15*	Full deflection
Maximum allowable force	N	50*	Full deflection
Rocker operating angle	°	± 10	
Rocker action		Self centering	
Expected life (operations)		> 5 million	
Weight	g	30	

*14mm radius from center

ENVIRONMENTAL

Operating temperature	°C	-25 to + 70
Storage temperature	°C	-40 to + 80
Environmental protection		
JC025		IP65 (when correctly panel sealed) IEC 60529
JC030		IP60 (when correctly panel sealed) IEC 60529

Units supplied with O ring seal

ELECTRICAL

Analogue Track

Resolution		Virtually infinite
Track resistance (± 20%)	kΩ	1.8, 2, 2.9 or 5
Track electrical angle	°	± 9
Output voltage range	%	0-100, 10-90 or 25-75 of input (± 2%)
Center tap voltage (no load)	%	48 - 52 of applied voltage
Center tap angle	°	1.5 either side of center
Supply voltage - maximum	Vdc	22
Wiper circuit impedance	MΩ	Greater than 0.1**
Power dissipation @ 25°C	W	0.25 (no load)

** The long life resistive elements require a high impedance load in the wiper circuit to minimise the current flowing through the wiper for optimum conditions

Switch -

Directional or Center Off

Switch operating angle	°	2.5 either side of center
Supply voltage - maximum	Vdc	35
Load current - maximum	mA	5 resistive (or 200 with reduced switch life of 1 million operations)

ORDERING CODES

JC025 - - - BLK

Track resistance
N = 1.8k 0-100%
E = 5k 0-100%
R = 2k 10-90%
Q = 2.9k 25-75%

Rocker profile
STD = standard
V00 = V profile

JC030 - - V00 - BLK

Track resistance

No option on rocker profile for JC030

N = 1.8k 0-100%

E = 5k 0-100%

R = 2k 10-90%

Q = 2.9k 25-75%

DIMENSIONS AND MOUNTING OPTIONS

JC025

It is recommended that the JC025 is fitted from the back of the mounting panel using four M3 x 6mm female, self-clinching stand-offs (e.g. PEM ref. CSS M3-6) fitted to the back of the panel at opposite positions. The stand-offs are used in conjunction with four M3 x 6mm pan head screws. The panel cut-out and centers for the stand-offs are as shown in the panel mounting detail below.

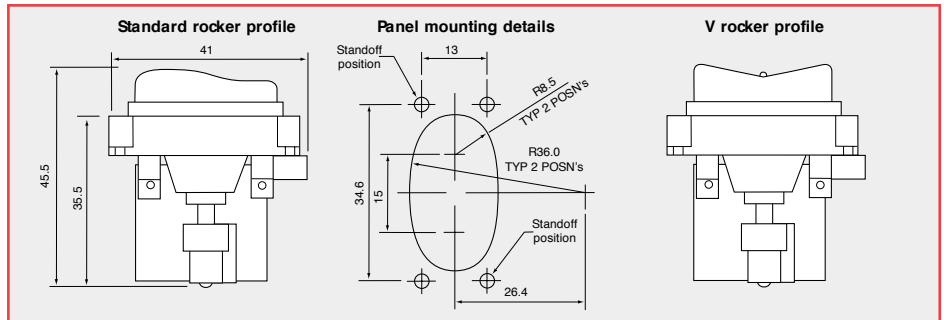

The recommended panel thickness is 3mm. The O ring supplied must be used to seal the JC025 rocker assembly to the mounting panel to enable IP65 protection.

JC030 - V profile only

It is recommended that the JC030 is fitted from the back of the mounting panel using four thread forming screws (supplied). Tighten the screws until initial contact with the body occurs ensuring body/flange relationship is square and flat. Continue tightening in 1/4 turn increments until a torque of 0.1 - 0.15Nm is achieved. The panel cut-out and centers are as shown below.

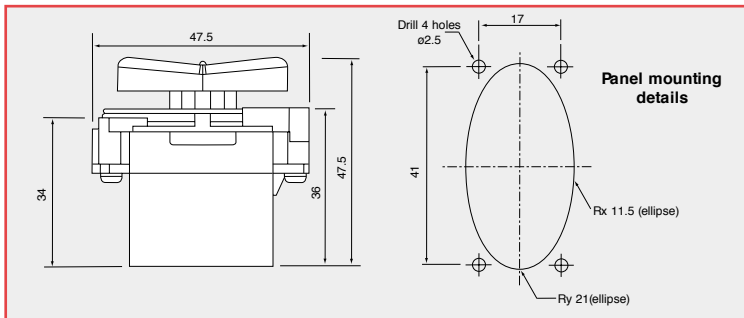

The recommended panel thickness is 3mm. The O ring supplied must be used to seal the JC030 rocker assembly to the mounting panel to enable IP60 protection. Supplied with 4 x panhead Pozidrive self tapping screws for mounting to panel.

Penny+ Giles has designed the JC030 to meet IP60 rating, but it is the final responsibility of the customer to approve the product in it's application.

ELECTRICAL CONNECTIONS

PTFE insulated 7/0.120 (28AWG) flying leads, 300mm long

Description

Positive voltage supply
Center tap
Negative or zero voltage supply
Output voltage signal
N/O switch, rocker backward
N/O switch, rocker forward
Common terminal for switch

Wire color

Pink/Grey
Yellow/Red
White/Red
Pink
Green
Blue/Orange
Black