

N RH 280 DP

dual output no contact rotary sensor



PERFORMANCE

ELECTRICAL

Measurement range	°	20 to 360 in 1° increments
Supply voltage	Vdc	9 to 30 (unregulated) and 5 ± 0.5 (regulated)
Over voltage protection	Vdc	Up to 40 (-40 to +60°C)
Maximum supply current	mA	< 25
Reverse polarity protection		Yes
Short circuit protection		
Output to GND		Yes
Output to supply		In 5V regulated mode only
Power-on settlement time	S	< 1
Resolution	%	0.025 of measurement range (12 bit)
Non-linearity*	%	< ± 0.4
Temperature coefficient	ppm/°C	< ± 30 in 5V supply mode; < ± 90 in 9-30V supply mode

*Non-linearity is measured using the least-squares method on a computerised calibration system

Analog Output (order code A1, A4) – see graph on page 31

Voltage output range		
9-30V supply	Vdc	Absolute voltage, 0.5 to 4.5 (A1) or 0.1 to 4.9 (A4) over measurement range (± 3%)
5V supply	Vdc	Ratiometric output voltage - 10 to 90% (A1) or 2 to 98% (A4) of Vs over measurement range (± 1%)
Monotonic range	Vdc	0.25 (5%) and 4.75 (95%) nominal (A1)
	Vdc	0.05 (1%) and 4.95 (99%) nominal (A4)
Load resistance	Ω	10k minimum (resistive to GND)
Output noise	mVrms	< 1
Input/output delay	mS	< 2

PWM Output (order code Pn) – see output characteristics on page 31

PWM frequency	Hz	244 (P1); 500 (P2); or 1000 (P3) ± 20% over temperature range
PWM levels 9-30V supply	Vdc	0 and 5 nominal (± 3%)
5V supply	Vdc	0 and Vs (± 1%)
Duty cycle	%	10 to 90 over measurement range
Monotonic range	%	5 and 95 nominal
Load resistance	Ω	10k minimum (resistive to GND)
Rise/fall time	µS	< 15

MECHANICAL

Mechanical angle	°	360, continuous
Maximum rotational speed	°/sec	3600
Weight	g	< 55 (with bolt type magnet carrier)
Mounting		Use 2 x M4 socket head cap screws and M4 washer - maximum tightening torque 2Nm. Bolt (B) or plug (P) type magnet holders are available for the customer to assemble to their own equipment. We also offer a magnet only (M) option for OEM's to integrate into their design.
Phasing		When magnet ident mark is facing toward the sensor and cable exit, output is at mid travel. The sensor housing allows for ± 10° adjustment via the mounting flange slots.

ENVIRONMENTAL

Protection class		IP68 (to 2m depth for 2 hours) and IP69K
Life		This product has no contacting parts.
Dither life		Contactless - no degradation due to shaft dither
Operational temperature[†]	°C	-40 to + 140 (5V supply) and + 170°C for 72 hours -40 to + 135.2 (9V supply option) Derate upper temperature limit by 1.7°C for every 1V increase in supply; e.g. -40 to + 100 @30V
Storage temperature	°C	-55 to + 140
Vibration		BS EN 60068-2-64:1995 Sec 8.4 (31.4gn rms) 20 to 2000Hz Fandom
Shock		3m drop onto concrete and 2500g
EMC Immunity level		BS EN 61000-4-3:1999, to 100V/m, 80MHz to 1GHz and 1.4GHz to 2.7GHz (2004/108/EC)

[†] See Maximum Operating Temperature – derating graph on page 30.

If the maximum operating temperature is exceeded, the voltage regulator will shut down to protect the device from overheating

OPTIONS

Measurement range (angle)		Select from 20° to 360° in 1° increments (factory programmed) for each output channel
Output		Analog voltage (An) or PWM (Pn)
Output direction		Both clockwise, both anticlockwise or one CW, one ACW
Magnet holder		Bolt (B) or plug (P) types, or magnet only (M)
Cable length	m	0.5
OEM options		Outputs can be programmed to provide: non linear laws; switch outputs; clamp voltages; different output phasing CH1/CH2; faster input/output delay; extended analog range; and output mapping for potentiometer replacements.

AVAILABILITY

All standard configurations can be supplied rapidly from the factory – check with your local supplier for more details

ORDERING CODES

		NRH280DP//...../...../...../...../.....
Measurement range	CH1 = angle in °	_____
Measurement range	CH2 = angle in °	_____
Output	A1 = Analog 0.5-4.5Vdc A4 = Analog 0.1-4.9Vdc P1 = PWM, 244Hz P2 = PWM, 500Hz P3 = PWM, 1000Hz	_____
Direction	3 = Both clockwise 4 = Both anticlockwise 5 = CH1 CW; CH2 ACW	_____
Magnet holder	B = Bolt type P = Plug type M = Magnet only	_____
Cable length	F5 = 0.5m	_____

N RH 280 DP

DIMENSIONS

Note: drawings not to scale

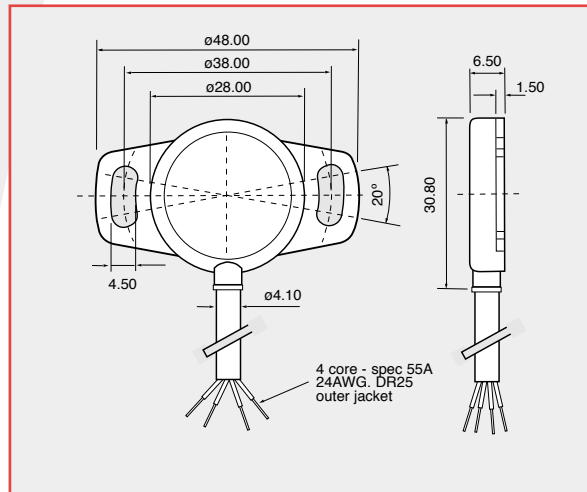

MAGNET HOLDER OPTIONS

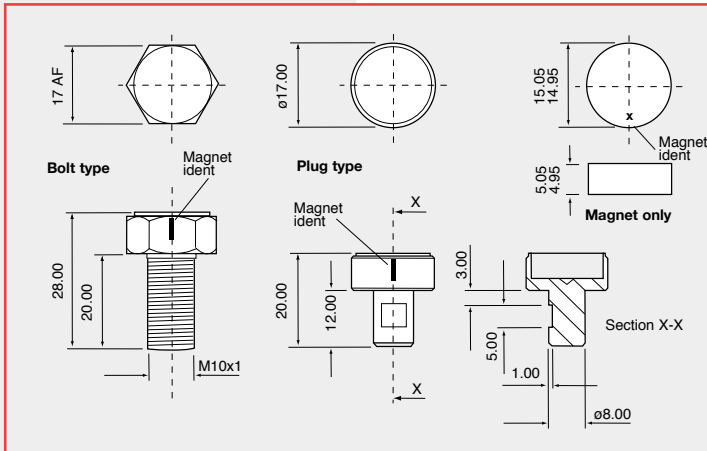

ELECTRICAL ANGLE

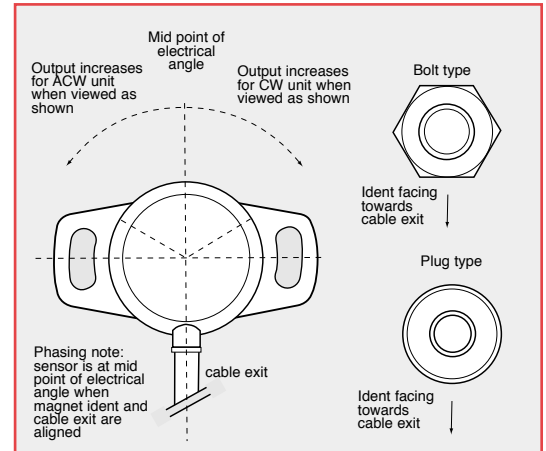

MAGNET MISALIGNMENT

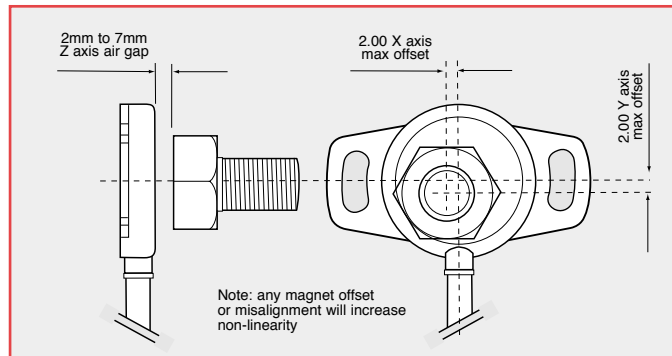

ELECTRICAL CONNECTIONS

500mm of 4-core cable: FDR25 sheathed, with 55A spec (24AWG) cores

Cable colour	Description
Red	+ V Supply
Yellow	Output 1
White	Output 2
Black	0V Supply (GND)

When connecting the sensor, care should be taken with the correct connections. The sensor is provided with reverse polarity protection and short circuit protection between outputs (Yellow & White) to GND (Black), **but if the outputs (Yellow & White) are connected to the supply this will result in device failure.**

Output increases with CW or ACW rotation viewed on sensor face - depending on selected order code

TEMPERATURE AND OUTPUT GRAPHS

MAXIMUM OPERATING TEMPERATURE - DERATING GRAPHS

SRH280P

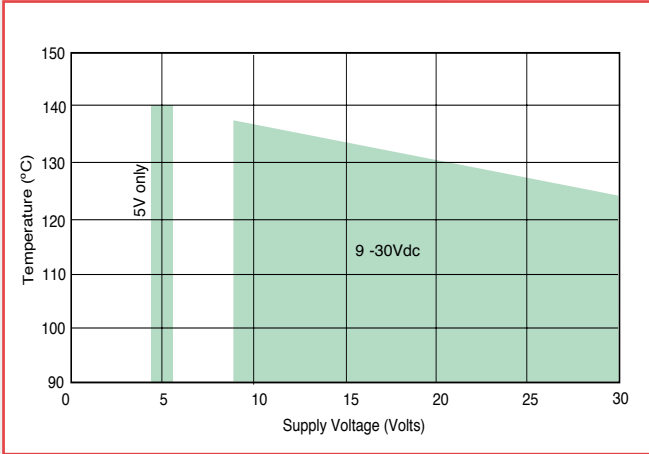

**SRH280DP, NRH280DP, TPS280DP, SRH220DR
SRH501P/502P (not A2 & A3 options)**

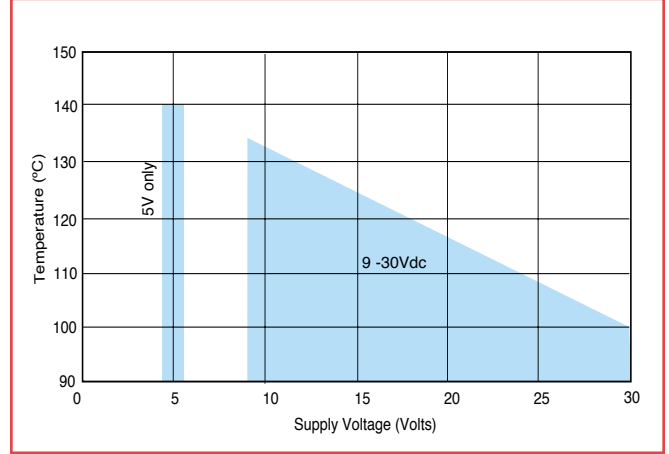

SRH220DR, SRH501P/502P - OUTPUT A2

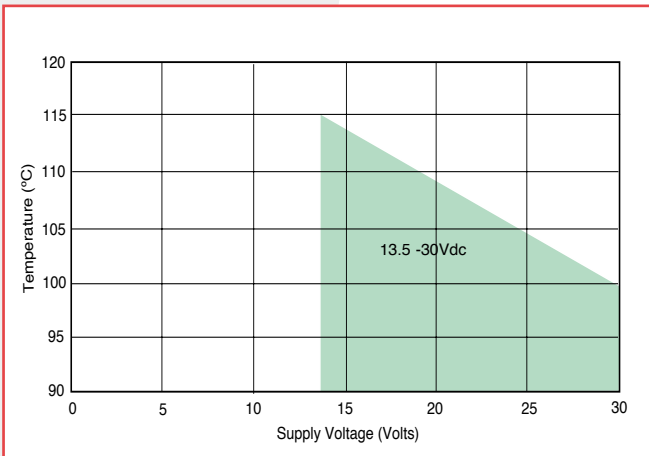

SRH501P/502P - OUTPUT A3

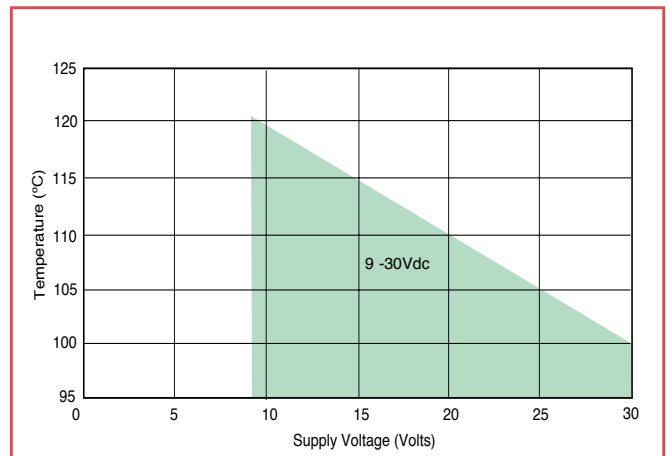

A3 Typical temperature slope characteristic (can be used for compensation)

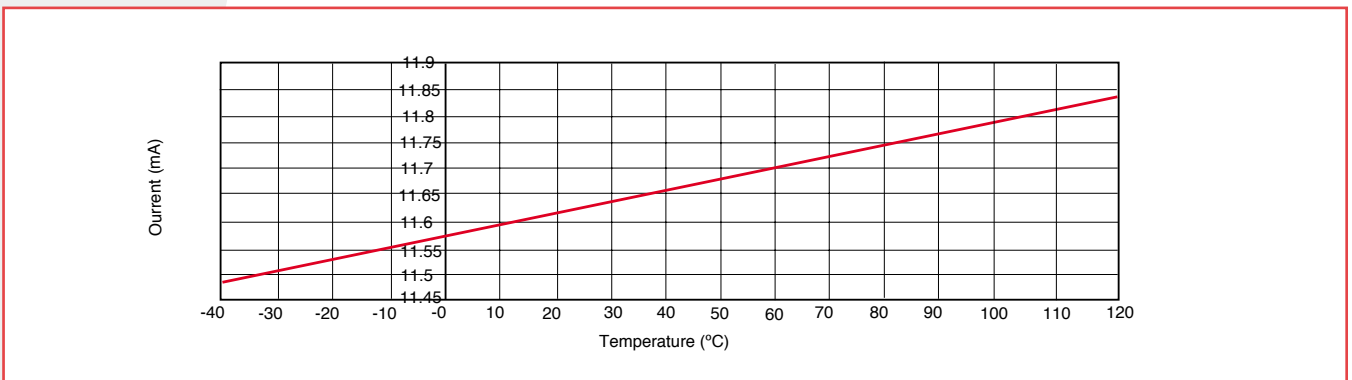

SENSOR OUTPUT GRAPH- examples for three different angles

SRH280P, SRH280DP, NRH280DP, NRH285DR, TPS280DP, SRH220DR - OUTPUT A1
 SRH501P/502P - OUTPUT A1
 SRH880P - OUTPUT A

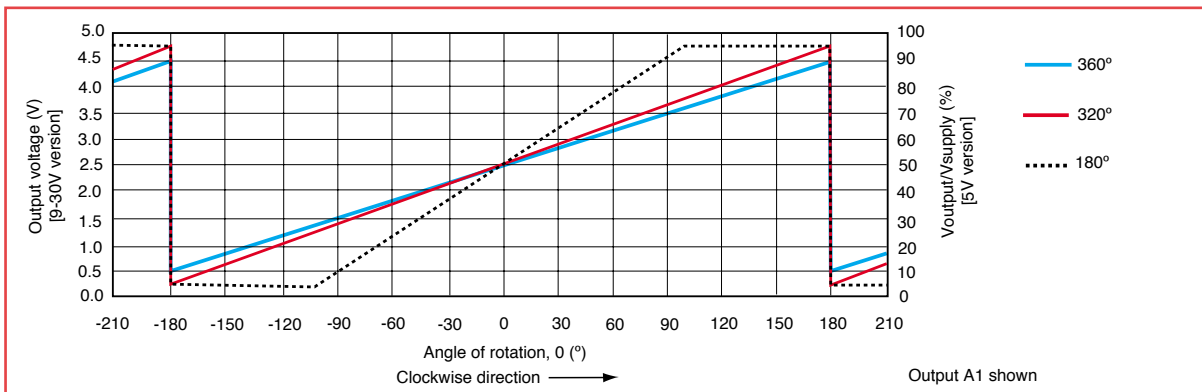

SRH220DR, SRH501P/502P - OUTPUT A2 (0-10Vdc)

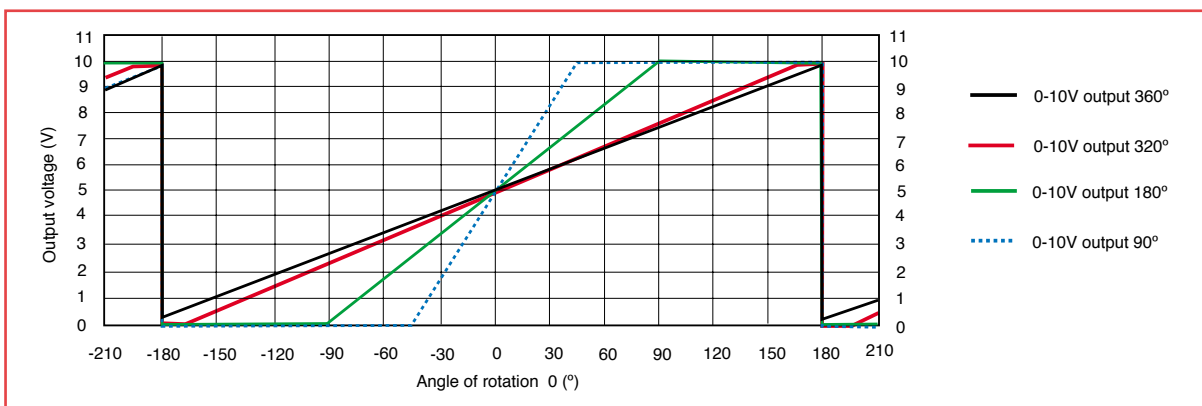

SRH501P/502P - OUTPUT A3 (4-20mA)

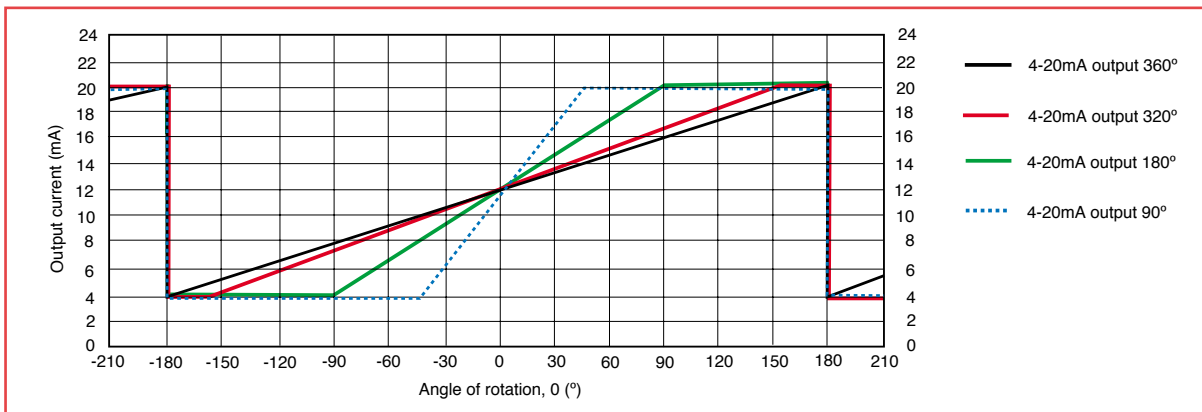

PWM OUTPUT CHARACTERISTICS

SRH280P, SRH280DP, NRH280DP, NRH285DR, TPS280DP, SRH220DR - OUTPUT P1, P2, P3
 SRH501P/502P - OUTPUT P1, P2, P3
 SRH880P - OUTPUT P

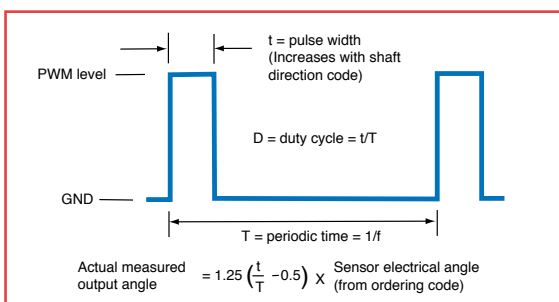

PWM levels = zero volt and 5V ($\pm 3\%$) for 9-30V supply
 = zero volt and V_S ($\pm 1\%$) for 5V supply