



CONTACTLESS ROTARY POSITION SENSORS

INNOVATION IN MOTION

The Penny+Giles contactless rotary position sensors have been specially developed to provide maximum performance under extremes of temperature, humidity, vibration, shock and immersion. Using the latest advances in 12bit Hall effect sensing technology, this expanded range of new generation sensors are factory programmed to provide the user with a wide range of previously unavailable options, including single or dual redundant outputs, clockwise or anticlockwise rotation and measurement angles from 0-20° to 0-360° in 1° increments.

This sensor range is ideally suited to operate in extremely hostile applications that are typical in motorsport, off-road specialist vehicles, military vehicles and heavy industrial machinery.

Contactless magnetic rotary sensor IC

The NRH/TPS/SRH series use a high performance, factory programmable 12 bit magnetic rotary sensor IC that includes integrated Hall elements and digital signal processing. The angular position information is provided by a magnet integrated with the sensor's shaft, or supplied separately. The sensor provides a pulse width modulated signal or an absolute analog voltage signal. Most models are designed to operate from either a 5Vdc regulated or 9-30Vdc unregulated supply, with a high stability circuit and EMC immunity to 100V/m.



Features

- Contactless technology
- Absolute analog or digital (PWM) output
- Measuring range from 20° to 360° in 1° increments
 - Single or Dual outputs
- Temperature error less than 50ppm/°C
 - Rugged housing and shaft designs
 - Protection up to IP69K
- Choice of shaft attachments and mountings
 - Rapid despatch of any option
 - CE approved

Benefits

- Long life and impervious to dither vibration
- No loss of position on power down
- Maximum sensitivity in all applications
- Optional redundant output for safety critical applications
- Maximises system accuracy over temperature range
- Suitable for extreme environments
- Operation in hostile environments including pressure washing
- Interchangeable with existing installations
- Eliminates customer inventory
- Confidence in EMC performance



EMC Directive 2004/108/EEC

The products detailed in this document have been tested to the requirements of EN 61000-4-3 (Immunity).



Quality Assurance

Penny+Giles are accredited to BS EN ISO9001:2008. Quality is at the heart of all our systems ensuring the reliability of our products from initial design to final despatch.

Certificate No. LRQ 0924881

Design Statement

The design of models SRH501P and SRH502P are subject to Community Registered Design No 000961610-0001.

The majority of our designs include an input protector circuit (Patent number GB2418083).

Innovative, rugged designs - superior protection

All models in our range have been designed to offer the best combination of materials and mounting styles that ensure survivability in the most rugged applications. We use sealing systems and cable connections that offer superior protection against the most hostile of operating conditions.

Impressive environmental capability

Designed with 21st century applications in mind most of our models can withstand operating temperatures from -40°C to +140°C (+170°C for 72 hours with our NRH and TPS models) and have been tested to withstand severe shock and vibration. All sensors have protection to at least IP68 rating, with some models offering protection to IP69K. With an EMC immunity of 100V/m, these position sensors are ready for the harshest applications.

Superior performance

This range of sensors has an impressive performance specification and most can operate from a 5Vdc regulated or 9 – 30Vdc supply.

Outputs can be PWM or analog voltage (nominal 0.5 - 4.5Vdc) over the measurement range, with clockwise or anticlockwise shaft rotation. A choice of 341 different electrical angles from 20° to 360° are possible. 12 bit resolution (0.025%) is available over the selected measuring range, with a non-linearity better than $\pm 0.4\%$ and temperature stability better than $\pm 50\text{ppm}/^\circ\text{C}$. The sensor's analog output option has a very low output noise level of less than 1mV rms.

World leading availability

All models have been 'designed for manufacture' which enables assembly in state-of-the-art manufacturing cells. This means that we can supply any of the configurations possible from the options offered, in a matter of days from ordering. This allows OEMs to reduce or eliminate their inventory, and call on Penny+Giles to supply 'on demand'.

Performance assured*

Penny+Giles product development process includes exhaustive qualification testing to ensure that performance specifications published in our product brochures and technical data sheets are backed by real-life test evidence. This is our assurance to you that our designs have been tested at these parameters.

* The qualification and suitability of these products in any customer specific application is the responsibility of the customer, unless otherwise agreed with Penny+Giles.

Selection Guide

Penny+Giles offers the widest choice of options to suit your unique application. We can also offer a custom design service if one of our standard models does not suit your requirements.

NRH280DP



- Dual output
- 6.5mm deep with metal flange
- Separate magnet assembly
- Sealed to IP69K
- Raychem™ DR25 cable

NRH285DR



- Dual input/dual output version of NRH280DP
- 5Vdc operation only

SRH220DR



- Dual input/dual output
- 28 x 38mm body with crush proof flange
- Sealed to IP68
- Integrated connector

SRH280P



- Single output
- 28mm body with crush proof flange
- Three shaft styles
- Sealed to IP68

SRH280DP



- Dual output
- Raychem™ DR25 cable
- 28mm body with crush proof flange
- Three shaft styles
- Sealed to IP68

TPS280DP



- Dual output
- D drive
- Sealed to IP68
- 25mm body with crush proof flange
- Raychem™ DR25 cable+connector

SRH501P



- Single output
- 87.5mm mounting flange
- Marine grade alloy housing
- Sealed to IP69K

SRH502P



- Dual output
- 87.5mm mounting flange
- Marine grade alloy housing
- Sealed to IP69K

SRH880P

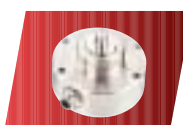

- Single output
- 88 mm body
- Aluminum or stainless steel housing
- Sealed to IP68M

NRH280DP

dual output no contact rotary sensor



PERFORMANCE

ELECTRICAL

Measurement range	°	20 to 360 in 1° increments
Supply voltage	Vdc	9 to 30 (unregulated) and 5 ±0.5 (regulated)
Over voltage protection	Vdc	Up to 40 (-40 to +60°C)
Maximum supply current	mA	<25
Reverse polarity protection		Yes
Short circuit protection		
Output to GND		Yes
Output to supply		In 5V regulated mode only
Power-on settlement time	S	<1
Resolution	%	0.025 of measurement range (12 bit)
Non-linearity*	%	< ±0.4
Temperature coefficient	ppm/°C	< ±30 in 5V supply mode; < ±90 in 9-30V supply mode

*Non-linearity is measured using the least-squares method on a computerised calibration system

Analog Output (order code A1, A4) – see graph on page 31

Voltage output range		
9-30V supply	Vdc	Absolute voltage, 0.5 to 4.5 (A1) or 0.1 to 4.9 (A4) over measurement range (±3%)
5V supply	Vdc	Ratiometric output voltage - 10 to 90% (A1) or 2 to 98% (A4) of Vs over measurement range (±1%)
Monotonic range	Vdc	0.25 (5%) and 4.75 (95%) nominal (A1)
	Vdc	0.05 (1%) and 4.95 (99%) nominal (A4)
Load resistance	Ω	10k minimum (resistive to GND)
Output noise	mVrms	<1
Input/output delay	mS	<2

PWM Output (order code Pn) – see output characteristics on page 31

PWM frequency	Hz	244 (P1); 500 (P2); or 1000 (P3) ±20% over temperature range
PWM levels 9-30V supply	Vdc	0 and 5 nominal (±3%)
5V supply	Vdc	0 and Vs (±1%)
Duty cycle	%	10 to 90 over measurement range
Monotonic range	%	5 and 95 nominal
Load resistance	Ω	10k minimum (resistive to GND)
Rise/fall time	µS	<15

MECHANICAL

Mechanical angle	°	360, continuous
Maximum rotational speed	°/sec	3600
Weight	g	<55 (with bolt type magnet carrier)
Mounting		Use 2 x M4 socket head cap screws and M4 washer - maximum tightening torque 2Nm. Bolt (B) or plug (P) type magnet holders are available for the customer to assemble to their own equipment. We also offer a magnet only (M) option for OEM's to integrate into their design.
Phasing		When magnet ident mark is facing toward the sensor and cable exit, output is at mid travel. The sensor housing allows for ±10° adjustment via the mounting flange slots.

ENVIRONMENTAL

Protection class		IP68 (to 2m depth for 2 hours) and IP69K
Life		This product has no contacting parts.
Dither life		Contactless - no degradation due to shaft dither
Operational temperature¹	°C	-40 to +140 (5V supply) and +170°C for 72 hours -40 to +135.2 (9V supply option) Derate upper temperature limit by 1.7°C for every 1V increase in supply; e.g. -40 to +100 @30V
Storage temperature	°C	-55 to +140
Vibration		BS EN 60068-2-64:1995 Sec 8.4 (31.4gn rms) 20 to 2000Hz Random
Shock		3m drop onto concrete and 2500g
EMC Immunity level		BS EN 61000-4-3:1999, to 100V/m, 80MHz to 1GHz and 1.4GHz to 2.7GHz (2004/108/EC)

¹ See Maximum Operating Temperature – derating graph on page 30.

If the maximum operating temperature is exceeded, the voltage regulator will shut down to protect the device from overheating

OPTIONS

Measurement range (angle)		Select from 20° to 360° in 1° increments (factory programmed) for each output channel
Output		Analog voltage (An) or PWM (Pn)
Output direction		Both clockwise, both anticlockwise or one CW, one ACW
Magnet holder		Bolt (B) or plug (P) types, or magnet only (M)
Cable length	m	0.5
OEM options		Outputs can be programmed to provide: non linear laws; switch outputs; clamp voltages; different output phasing CH1/CH2; faster input/output delay; extended analog range; and output mapping for potentiometer replacements.

AVAILABILITY

All standard configurations can be supplied rapidly from the factory – check with your local supplier for more details

ORDERING CODES

		NRH280DP/...../...../...../...../...../.....
Measurement range	CH1 = angle in °	_____●
Measurement range	CH2 = angle in °	_____●
Output	A1 = Analog 0.5-4.5Vdc A4 = Analog 0.1-4.9Vdc P1 = PWM, 244Hz P2 = PWM, 500Hz P3 = PWM, 1000Hz	_____●
Direction	3 = Both clockwise 4 = Both anticlockwise 5 = CH1 CW; CH2 ACW	_____●
Magnet holder	B = Bolt type P = Plug type M = Magnet only	_____●
Cable length	P5 = 0.5m	_____●

NRH280DP

DIMENSIONS

Note: drawings not to scale

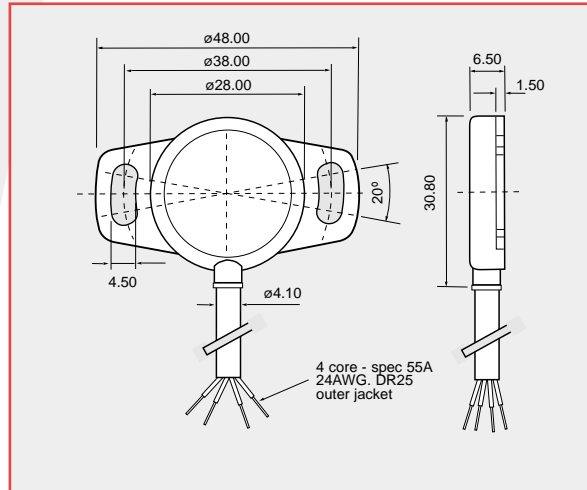

MAGNET HOLDER OPTIONS

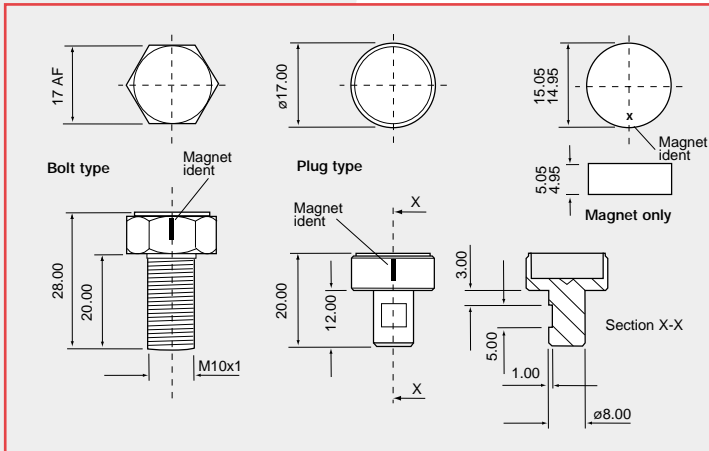

ELECTRICAL ANGLE

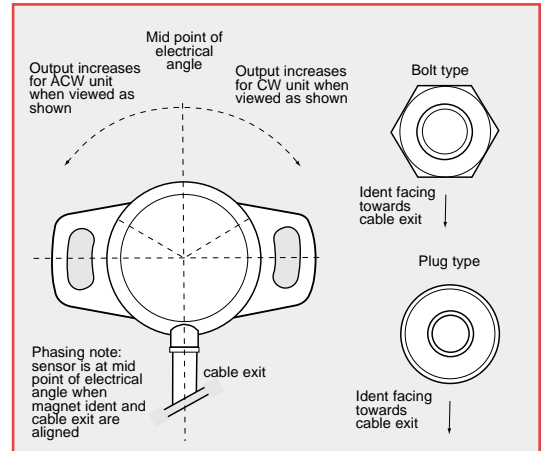

MAGNET MISALIGNMENT

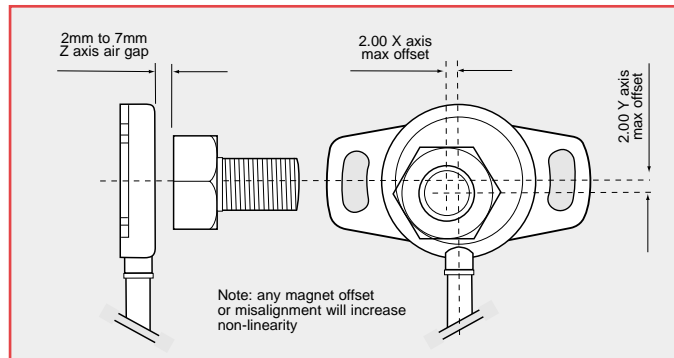

ELECTRICAL CONNECTIONS

500mm of 4-core cable: FDR-25 sheathed, with 55A spec (24AWG) cores

Cable colour	Description
Red	+V Supply
Yellow	Output 1
White	Output 2
Black	0V Supply (GND)

When connecting the sensor, care should be taken with the correct connections. The sensor is provided with reverse polarity protection and short circuit protection between outputs (Yellow & White) to GND (Black), **but if the outputs (Yellow & White) are connected to the supply this will result in device failure.**

Output increases with CW or ACW rotation viewed on sensor face - depending on selected order code

NRH285DR DUAL REDUNDANT OUTPUT

no contact rotary sensor – 5Vdc operation only



PERFORMANCE

ELECTRICAL

Measurement range	°	20 to 360 in 1° increments
Supply voltage	Vdc	5 ±0.5 (regulated) to each independent sensor channel
Over voltage protection	Vdc	Up to 10 (-40 to +60°C)
Maximum supply current	mA	< 12.5 each independent supply (< 25 total)
Reverse polarity protection		Yes
Short circuit protection		
Output to GND		Yes
Output to supply		Yes
Power-on settlement time	S	< 1
Resolution	%	0.025 of measurement range (12 bit)
Non-linearity*	%	< ±0.4
Temperature coefficient	ppm/°C	< ±30

* Non-linearity is measured using the Least-Squares method on a computerised calibration system

Analog Output (order code A1, A4) – see graph on page 31

Voltage output range	Vdc	Ratiometric output voltage - 10 to 90% (A1) or 2 to 98% (A4) of Vs over measurement range (±1%)
Monotonic range	Vdc	0.25 (5%) and 4.75 (95%) nominal (A1)
	Vdc	0.05 (1%) and 4.95 (99%) nominal (A4)
Load resistance	Ω	10k minimum (resistive to GND)
Output noise	mVrms	< 1
Input/output delay	mS	< 2

PWM Output (order code Pn) – see output characteristics on page 31

PWM frequency	Hz	244 (P1); 500 (P2); or 1000 (P3) ±20% over temperature range
PWM levels 5V supply	Vdc	0 and Vs (±1%)
Duty cycle	%	10 to 90 over measurement range
Monotonic range	%	5 and 95 nominal
Load resistance	Ω	10k minimum (resistive to GND)
Rise/fall time	µS	< 15

MECHANICAL

Mechanical angle	°	360, continuous
Maximum rotational speed	°/sec	3600
Weight	g	< 55 (with bolt type magnet carrier)
Mounting		Use 2 x M4 socket head cap screws and M4 washer - maximum tightening torque 2Nm. Bolt (B) or plug (P) type magnet holders are available for the customer to assemble to their own equipment. We also offer a magnet only (M) option for OEM's to integrate into their design.
Phasing		When magnet ident mark is facing toward the sensor and cable exit, output is at mid travel. The sensor housing allows for ±10° adjustment via the mounting flange slots.

NRH285DR

ENVIRONMENTAL

Protection class		IP68 (to 2m depth for 2 hours) and IP69K
Life		This product has no contacting parts.
Dither life		Contactless - no degradation due to shaft dither
Operational temperature*	°C	-40 to +140 and +170°C for 72 hours
Storage temperature	°C	-55 to +140
Vibration		BS EN 60068-2-64:1995 Sec 8.4 (31.4gn rms) 20 to 2000Hz Random
Shock		3m drop onto concrete and 2500g
EMC Immunity level		BS EN 61000-4-3:1999, to 100V/m, 80MHz to 1GHz and 1.4GHz to 2.7GHz (2004/108/EC)

* If the maximum operating temperature is exceeded, the voltage regulator will shut down to protect the device from overheating

OPTIONS

Measurement range (angle)		Select from 20° to 360° in 1° increments (factory programmed) for each output channel
Output		Analog voltage (An) or PWM (Pn)
Output direction		Both clockwise, both anticlockwise or one CW, one ACW
Magnet holder		Bolt (B) or plug (P) types, or magnet only (M)
Cable length	m	0.5
OEM options		Outputs can be programmed to provide: non linear laws; switch outputs; clamp voltages; different output phasing CH1/CH2; faster input/output delay; extended analog range; and output mapping for potentiometer replacements.

AVAILABILITY

All standard configurations can be supplied rapidly from the factory – check with your local supplier for more details

ORDERING CODES

			NRH285DR/...../...../...../...../...../.....
Measurement range	CH1 = angle in °		
Measurement range	CH2 = angle in °		
Output	A1 = Analog 0.5-4.5Vdc A4 = Analog 0.1-4.9Vdc P1 = PWM, 244 Hz P2 = PWM, 500 Hz P3 = PWM, 1000 Hz		
Direction	3 = Both clockwise 4 = Both anticlockwise 5 = CH1 CW; CH2 ACW		
Magnet holder	B = Bolt type P = Plug type M = Magnet only		
Cable length	P5 = 0.5m		

DIMENSIONS

Note: drawings not to scale

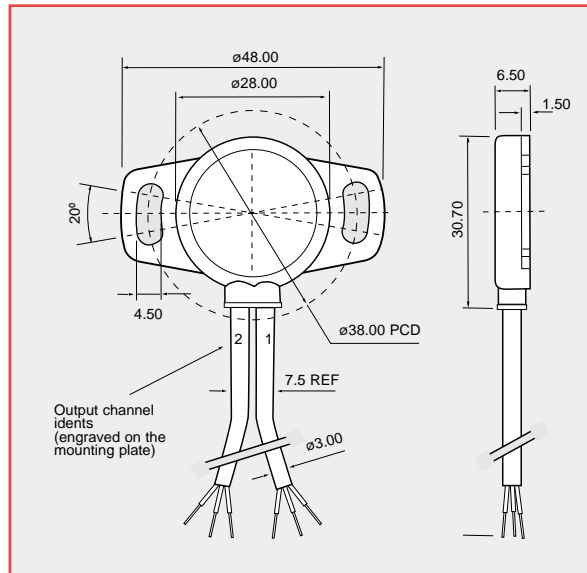

MAGNET HOLDER OPTIONS

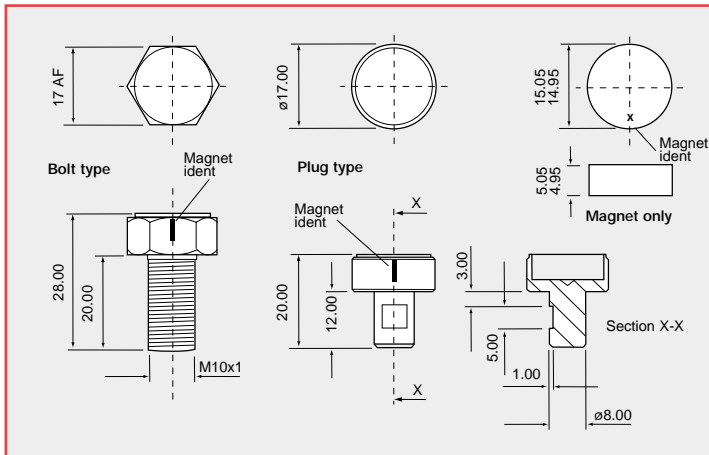

ELECTRICAL ANGLE

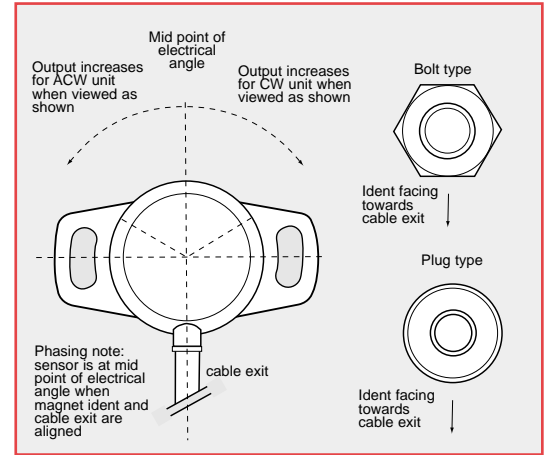

MAGNET MISALIGNMENT

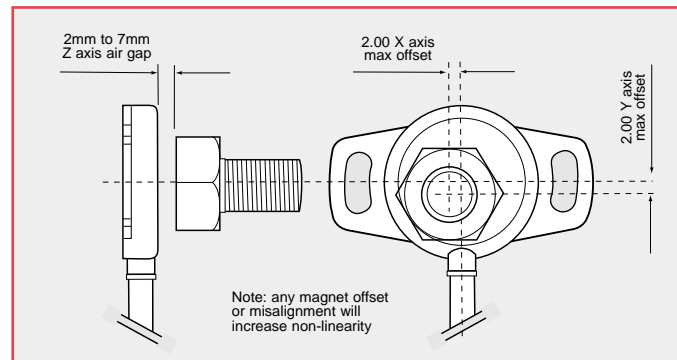

ELECTRICAL CONNECTIONS

2 x 500mm of 3-core cable: FDR-25 sheathed, with 55A spec (24AWG) cores

Cable colour *	Description
Red	+V Supply
Yellow	Output 1+2
Black	0V Supply (GND)

Output increases with CW or ACW rotation viewed on sensor face - depending on selected order code

*Cables are identified on the mounting plate. 1 = CH1, 2 = CH2

When connecting the sensor, care should be taken with the correct connections. The sensor is provided with reverse polarity protection and short circuit protection between outputs (Yellow) to GND (Black) and outputs to supply (Red) on NRH 285DR model only.

SRH220DR DUAL REDUNDANT OUTPUT

contactless rotary sensor



PERFORMANCE

Output options

A1 | A4 | P1 | P2 | P3
0.5-4.5 or 0.1-4.9Vdc | PWM

A2
0-10Vdc

ELECTRICAL

Measurement range	°	20 to 360 in 1° increments	20 to 360 in 1° increments
Supply voltage	Vdc	9 to 30 (unregulated) and 5 ±0.5 (regulated)	13.5 to 30 (unregulated)
Over voltage protection	Vdc	Up to 40 (-40 to +60°C)	Up to 40 (-40 to +60°C)
Maximum supply current	mA	<12.5 each independent supply (<25 total)	<30 (15 each channel)
Reverse polarity protection		Yes	Yes
Short circuit protection			
Output to GND		Yes	Yes
Output to supply		In 5V regulated mode only	Yes
Power-on settlement time	S	<1	<1
Resolution	%	0.025 of measurement range (12 bit)	0.025 of measurement range (12 bit)
Non-linearity*	%	<±0.4	<±0.4
Temperature coefficient	ppm/°C	<±30 (5V supply mode) <±110 (9-30V supply mode)	<±125

*Non-linearity is measured using the least-squares method on a computerised calibration system

Analog Voltage Output (order code A1, A4) - see graph on page 31

Voltage output range

9-30V supply	Vdc	Absolute voltage, 0.5 to 4.5 (A1) or 0.1 to 4.9 (A4) over measurement range (±3%)
5V supply	Vdc	Ratiometric output voltage - 10 to 90% (A1) or 2 to 98% (A4) of Vs over measurement range (±1%)
Monotonic range	Vdc	0.25 (5%) and 4.75 (95%) nominal (A1)
	Vdc	0.05 (1%) and 4.95 (99%) nominal (A4)
Load resistance	Ω	10k minimum (resistive to GND)
Output noise	mVrms	<1
Input/output delay	mS	<2

Analog Voltage Output (order code A2) - see typical graph on page 31

Voltage output range	Vdc	Absolute voltage, nominally 0.2 to 9.8 (±0.2V)
Load resistance	Ω	10k minimum (resistive to GND)
Output noise	mVrms	<1
Input/output delay	mS	3.5

PWM Output (order code Pn) - see output characteristics on page 31

PWM frequency	Hz	244 (P1); 500 (P2); or 1000 (P3) ±20% over temperature range
PWM levels	9-30V supply Vdc	0 and 5 nominal (±3%)
	5V supply Vdc	0 and Vs (±1%)
Duty cycle	%	10 to 90 over measurement range
Monotonic range	%	5 and 95 nominal
Load resistance	Ω	10k minimum (resistive to GND)
Rise/fall time	µS	<15

MECHANICAL

Mechanical angle	°	360, continuous
Operating torque	g-cm	120
Maximum rotational speed	°/sec	3600
Weight	g	<51
Mounting		Use 2 x M4 socket head cap screws and M4 washer - maximum tightening torque 2Nm
Phasing		When shaft drive detail is aligned as shown in Electrical Angle Diagram (page 12) output is at mid travel. The sensor housing allows for ±10° adjustment via the mounting flange slots.

ENVIRONMENTAL

Protection class		IP68 - with AMP connector option (when recommended mating part is fully connected) IP67 - with Deutsch connector option (when recommended mating part is fully connected)
Life		20 million operations (10 x 10 ⁶ cycles) of ±75°; sensing element life is essentially infinite (contactless)
Dither life		Contactless - no degradation due to shaft dither
Operational temperature[†]	°C	
Output A1, A4, P1-3		-40 to +140 (5V supply) -40 to +135.7 (9V supply) Derate upper temperature limit by 1.7°C for every 1V increase in supply: e.g. -40 to +100 @30V
Output A2		40 to +115 (13.5V supply) Derate upper temperature limit by 0.91°C for every 1V increase in supply: e.g. -40 to +100 @30V
Storage temperature	°C	-55 to +140
Vibration		BS EN 60068-2-64:1995 Sec 8.4 (31.4gn rms) 20 to 2000Hz Random
Shock		3m drop onto concrete and 2500g
EMC Immunity level		BS EN 61000-4-3:1999, to 100V/m, 80MHz to 1GHz and 1.4GHz to 2.7GHz (2004/108/EC)

[†] See Maximum Operating Temperature – Derating graph on page 30.

If the maximum operating temperature is exceeded, the voltage regulator will shut down to protect the device from overheating

OPTIONS

Measurement range (angle)	Select from 20° to 360° in 1° increments (factory programmed) for each output channel
Output	Analog voltage (An) or PWM (Pn)
Output direction	Both clockwise, both anticlockwise or one CW, one ACW
Shaft style	D section shaft
Connector	AMP Superseal 1.5 (A) or Deutsch DT04-6P 6-way integrated connectors
Operating lever	An operating lever kit can be supplied separately. See details on page 12
OEM options	Outputs can be programmed to provide: non linear laws; switch outputs; clamp voltages; different output phasing CH1/CH2; faster input/output delay; extended analog range; and output mapping for potentiometer replacements. We can also supply mating connectors, subject to minimum quantities

AVAILABILITY

All standard configurations can be supplied rapidly from the factory – check with your local supplier for more details

ORDERING CODES

		SRH220DR/...../...../...../...../...../.....
Measurement range	CH1 = angle in °	_____
Measurement range	CH2 = angle in °	_____
Output	A1 = Analog 0.5-4.5Vdc A2 = Analog 0-10Vdc A4 = Analog 0.1-4.9Vdc P1 = PWM, 244 Hz P2 = PWM, 500 Hz P3 = PWM, 1000 Hz	_____
Direction	3 = Both clockwise 4 = Both anticlockwise 5 = CH1 CW; CH2 ACW 6 = CH1 ACW; CH2 CW	_____
Shaft style	D = D shaft	_____
Connector	A = AMP 1.5 Superseal D = Deutsch DT04-6P	_____

Accessories (order separately)

Drive lever kit – SA207538 (includes lever and dowel pin)

Recommended Mating Connectors (can be supplied for OEM customers)

AMP Superseal 1.5 Plug – Part 282090-1 (plus 6 x receptacle contacts to match your wire size)

Deutsch DT06 Plug – Part DT06-6S (plus 6 x socket contacts to match your wire size)

SRH220DR

DIMENSIONS

Note: drawings not to scale

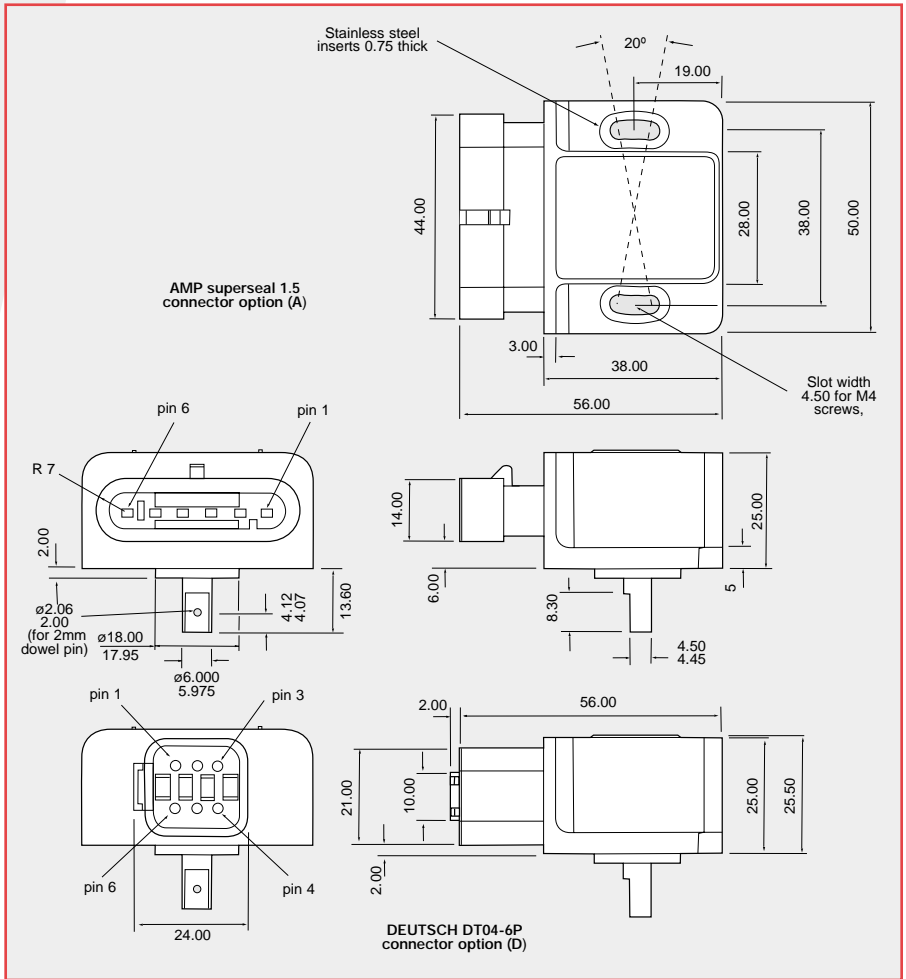

ELECTRICAL ANGLE

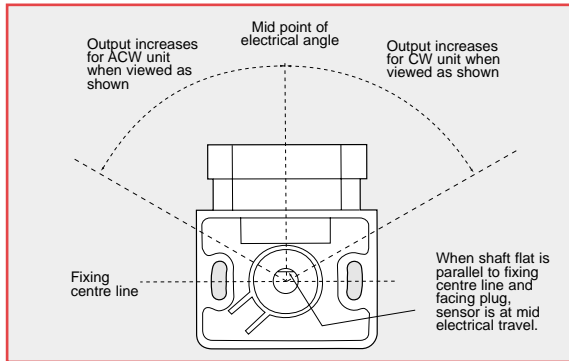

LEVER OPTION

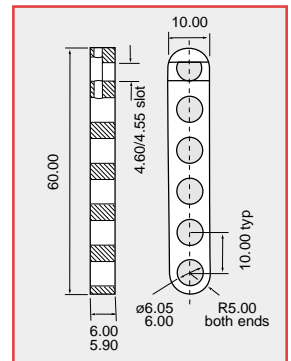

ELECTRICAL CONNECTIONS

Option A - AMP Superseal 1.5 connector
Option B - Deutsch DT04-6P connector

Mating connectors are not supplied

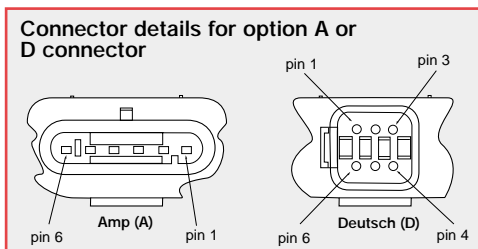

Pin No	Description
1	CH1 - 0V Supply (GND)
2	CH1 - +V supply
3	CH1 - Output
4	CH2 - 0V Supply (GND)
5	CH2 - +V Supply
6	CH2 - Output

When connecting the sensor, care should be taken with the correct connections. The sensor is provided with indefinite reverse polarity protection and short circuit protection between output to GND (Black), **but if the outputs are connected to the supply this will result in device failure.**

Output increases with CW or ACW rotation viewed on shaft - depending on selected order code.

SRH 280P SINGLE OUTPUT

contactless rotary sensor

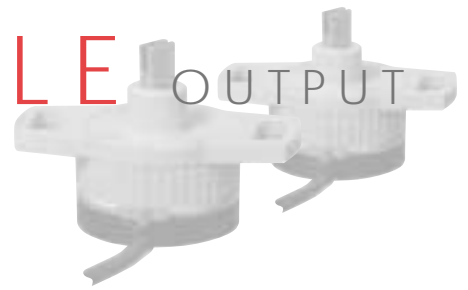

PERFORMANCE

ELECTRICAL

Measurement range	°	20 to 360 in 1° increments
Supply voltage	Vdc	9 to 30 (unregulated) and 5 ±0.5 (regulated)
Over voltage protection	Vdc	Up to 40 (-40 to +60°C)
Maximum supply current	mA	<12.5
Reverse polarity protection		Yes
Short circuit protection		
Output to GND		Yes
Output to supply		In 5V regulated mode only
Power-on settlement time	S	<1
Resolution	%	0.025 of measurement range (12 bit)
Non-linearity*	%	< ±0.4
Temperature coefficient	ppm/°C	< ±50

*Non-linearity is measured using the least-squares method on a computerised calibration system

Analog Output (order code A1, A4) - see graph on page 31

Voltage output range

9-30V supply	Vdc	Absolute voltage, 0.5 to 4.5 (A1) or 0.1 to 4.9 (A4) over measurement range (±3%)
5V supply	Vdc	Ratiometric output voltage - 10 to 90% (A1) or 2 to 98% (A4) of Vs over measurement range (±1%)
Monotonic range	Vdc	0.25 (5%) and 4.75 (95%) nominal (A1)
	Vdc	0.5 (1%) and 4.95 (99%) nominal (A4)
Load resistance	Ω	10k minimum (resistive to GND)
Output noise	mVrms	<1
Input/output delay	mS	<2

PWM Output (order code P) - See output characteristics on page 31

PWM frequency	Hz	244 (P1); 500 (P2); or 1000 (P3) ±20% over temperature range
PWM levels 9-30V supply	Vdc	0 and 5 nominal (±3%)
5V supply	Vdc	0 and Vs (±1%)
Duty cycle	%	10 to 90 over measurement range
Monotonic range	%	5 and 95 nominal
Load resistance	Ω	10k minimum (resistive to GND)
Rise/fall time	µS	<15

MECHANICAL

Mechanical angle	°	360, continuous
Operating torque - maximum		
sealed shaft IP68	g-cm	120
unsealed shaft IP50	g-cm	100
Shaft velocity maximum	°/sec	3600
Weight	g	<35
Mounting		Use 2 x M4 socket head cap screws and M4 washer - maximum tightening torque 2Nm
Phasing		When shaft flat (or shaft ident mark) is facing toward the cable exit, output is at mid travel. The sensor housing allows for ±10° adjustment via the mounting flange slots.

SRH280P

ENVIRONMENTAL

Protection class		IP68 (to 2m depth for 1 hour) or IP50
Life		20 million operations (10x10 ⁶ cycles) of ±75° Sensing element life is essentially infinite (contactless); the SRH280P life figure refers to the operating shaft seal. Mechanical load (axial and radial) on the shaft should also be considered.
Dither life		Contactless - no degradation due to shaft dither
Operational temperature[†]	°C	-40 to +140 (5V supply) -40 to +137 (9V supply) Derate upper temperature limit by 0.57°C for every 1V increase in supply: e.g. -40 to +125 @30V
Storage temperature	°C	-55 to +140
Vibration		BS EN 60068-2-64:1995 Sec 8.4 (14gn rms) 20 to 2000Hz Random
Shock		3m drop onto concrete
EMC Immunity level		BS EN 61000-4-3:1999, to 100V/m, 80MHz to 1GHz and 1.4GHz to 2.7GHz (2004/108/EC)

[†] See Maximum Operating Temperature – Derating graph on page 30
If the maximum operating temperature is exceeded, the voltage regulator will shut down to protect the device from overheating

OPTIONS

Measurement range (angle)		Select from 20° to 360° in 1° increments (factory programmed)
Output		Analog voltage (An) or PWM (Pn)
Output direction		Clockwise or Anticlockwise shaft rotation with increasing output
Shaft style		D section, sprung shaft (S) or 2.4mm blade shaft (H)
Shaft sealing		IP50 or IP68
Cable length	m	0.2, 0.5 or 2.0
Custom housing		Synchro mount style with ball race bearings - ask our technical sales team for details
OEM options		Output can be programmed to provide: non linear law; switch output; clamp voltages; faster input/output delay; extended analog range; and output mapping for potentiometer replacements

AVAILABILITY

All standard configurations can be supplied rapidly from the factory - check with your local supplier for more details

ORDERING CODES

			SRH280P/...../...../...../...../...../.....
Measurement range	= angle in °	
Output	A1 = Analog 0.5-4.5Vdc A4 = Analog 0.1-4.9Vdc P1 = PWM, 244 Hz P2 = PWM, 500 Hz P3 = PWM, 1000 Hz	
Direction	1 = Clockwise 2 = Anticlockwise	
Shaft style	D = D shaft S = Sprung shaft H = 2.4mm blade shaft	
Shaft sealing	50 = IP50 68 = IP68	
Cable length	P2 = 0.2m P5 = 0.5m O2 = 2.0m	

SRH280DP DUAL OUTPUT

contactless rotary sensor

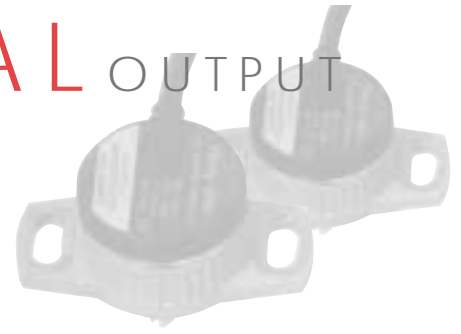

PERFORMANCE

ELECTRICAL

Measurement range	°	20 to 360 in 1° increments
Supply voltage	Vdc	9 to 30 (unregulated) and 5 ±0.5 (regulated)
Over voltage protection	Vdc	Up to 40 (-40 to +60°C)
Maximum supply current	mA	<25
Reverse polarity protection		Yes
Short circuit protection		
Output to GND		Yes
Output to supply		In 5V regulated mode only
Power-on settlement time	S	<1
Resolution	%	0.025 of measurement range (12 bit)
Non-linearity*	%	<±0.4
Temperature coefficient	ppm/°C	<±30 in 5V supply mode; <±90 in 9-30V supply mode

* Non-linearity is measured using the least-squares method on a computerised calibration system

Analog Output (order code A1, A4) – see graph on page 31

Voltage output range		
9-30V supply	Vdc	Absolute voltage, 0.5 to 4.5 (A1) or 0.1 to 4.9 (A4) over measurement range (±3%)
5V supply	Vdc	Ratiometric output voltage - 10 to 90% (A1) or 2 to 98% (A4) of Vs over measurement range (±1%)
Monotonic range	Vdc	0.25 (5%) and 4.75 (95%) nominal (A1)
	Vdc	0.05 (1%) and 4.95 (99%) nominal (A4)
Load resistance	Ω	10k minimum (resistive to GND)
Output noise	mVrms	<1
Input/output delay	mS	<2

PWM Output (order code Pn) – see output characteristics on page 31

PWM frequency	Hz	244 (P1); 500 (P2); or 1000 (P3) ±20% over temperature range
PWM levels	9-30V supply Vdc	0 and 5 nominal (±3%)
	5V supply Vdc	0 and Vs (±1%)
Duty cycle	%	10 to 90 over measurement range
Monotonic range	%	5 and 95 nominal
Load resistance	Ω	10k minimum (resistive to GND)
Rise/fall time	µS	<15

MECHANICAL

Mechanical angle	°	360, continuous
Operating torque - maximum		
sealed shaft IP68	g-cm	120
unsealed shaft IP50	g-cm	100
Shaft velocity maximum	°/sec	3600
Weight	g	<35
Mounting		Use 2 x M4 socket head cap screws and M4 washer - maximum tightening torque 2Nm
Phasing		When shaft flat (or shaft ident mark) is facing toward the cable exit, output is at mid travel. The sensor housing allows for ±10° adjustment via the mounting flange slots.

ENVIRONMENTAL

Protection class		IP68 (to 2m depth for 1 hour) or IP50
Life		20 million operations (10 x 10 ⁶ cycles) of ±75° Sensing element life is essentially infinite (contactless); the SRH280DP life figure refers to the operating shaft seal. Mechanical load (axial and radial) on the shaft should also be considered.
Dither life		Contactless - no degradation due to shaft dither
Operational temperature[†]	°C	-40 to +140 (5V supply) -40 to +135.7 (9V supply) Derate upper temperature limit by 1.7°C for every 1V increase in supply; e.g. -40 to +100 @30V
Storage temperature	°C	-55 to +140
Vibration		BS EN 60068-2-64:1995 Sec 8.4 (31.4gn rms) 20 to 2000Hz Random
Shock		3m drop onto concrete
EMC Immunity level		BS EN 61000-4-3:1999, to 100V/m, 80MHz to 1GHz and 1.4GHz to 2.7GHz (2004/108/EC)

[†] See Maximum Operating Temperature – derating graph on page 30.

If the maximum operating temperature is exceeded, the voltage regulator will shut down to protect the device from overheating

OPTIONS

Measurement range (angle)		Select from 20° to 360° in 1° increments (factory programmed) for each output channel
Output		Analog voltage (An) or PWM (Pn)
Output direction		Both clockwise, both anticlockwise or one CW, one ACW
Shaft style		D section, sprung shaft (S) or 2.4mm blade shaft (H)
Shaft sealing		IP50 or IP68
Cable length	m	0.2 or 0.5
Custom housing		Synchro mount style with ball race bearings - ask our technical sales team for details
OEM options		Outputs can be programmed to provide: non linear laws; switch outputs; clamp voltages; different output phasing CH1/CH2; faster input/output delay; extended analog range; and output mapping for potentiometer replacements

AVAILABILITY

All standard configurations can be supplied rapidly from the factory - check with your local supplier for more details

ORDERING CODES

		SRH280DP/...../...../...../...../...../...../.....
Measurement range	CH1 = angle in °	
Measurement range	CH2 = angle in °	
Output	A1 = Analog 0.5-4.5Vdc A4 = Analog 0.1-4.9Vdc P1 = PWM, 244 Hz P2 = PWM, 500 Hz P3 = PWM, 1000 Hz	
Direction	3 = Both clockwise 4 = Both anticlockwise 5 = CH1 CW; CH2 ACW	
Shaft style	D = D shaft S = Sprung shaft H = 2.4mm blade shaft	
Shaft sealing	50 = IP50 68 = IP68	
Cable length	P2 = 0.2m P5 = 0.5m	

SRH280DP

DIMENSIONS

Note: drawings not to scale

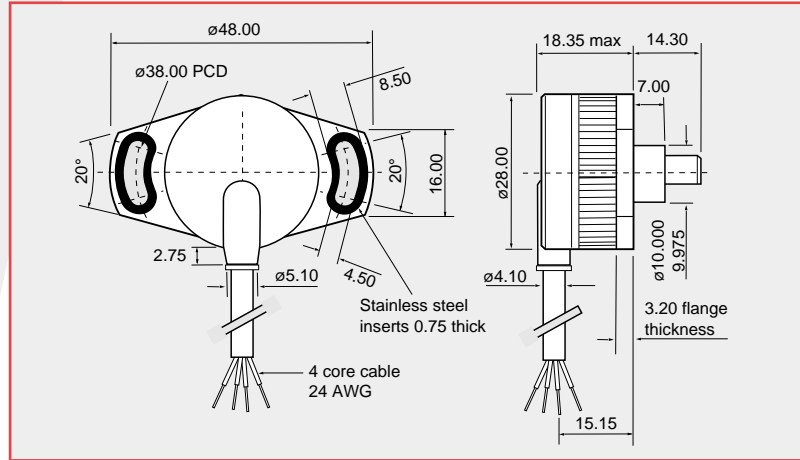

SHAFT OPTIONS

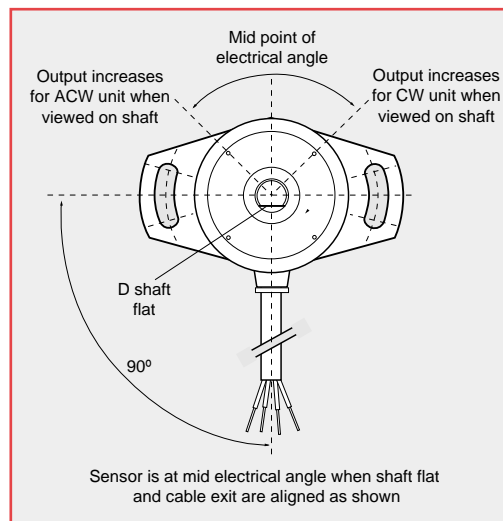
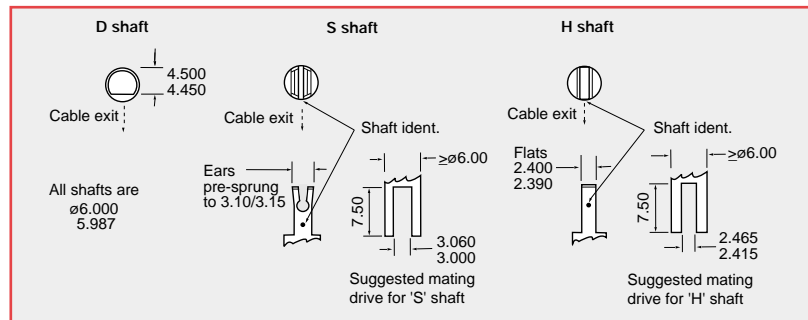

ELECTRICAL CONNECTIONS

200 or 500mm of 4-core cable: FDR-25 sheathed, with 55A spec (24AWG) cores

Cable colour	Description
Red	+V Supply
Yellow	Output 1
White	Output 2
Black	0V Supply (GND)

When connecting the sensor, care should be taken with the correct connections. The sensor is provided with reverse polarity protection and short circuit protection between outputs (Yellow & White) to GND (Black), **but if the outputs (Yellow & White) are connected to the supply this will result in device failure.**

Output increases with CW or ACW rotation viewed on shaft - depending on selected order code.

TPS280DP DUAL OUTPUT

contactless throttle position/rotary sensor

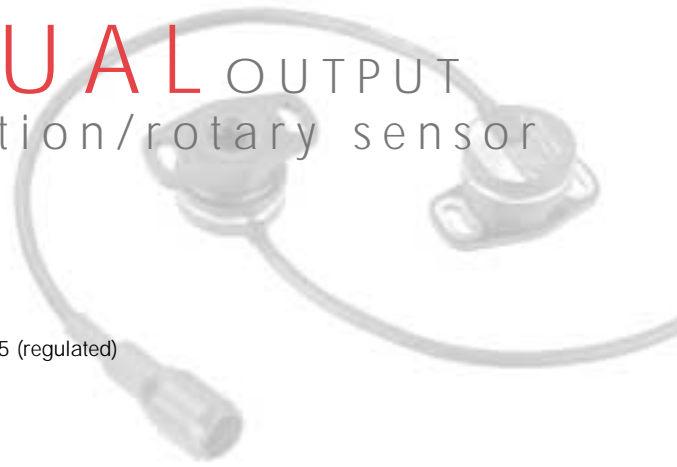

PERFORMANCE

ELECTRICAL

Measurement range	°	20 to 360 in 1° increments
Supply voltage	Vdc	9 to 30 (unregulated) and 5 ±0.5 (regulated)
Over voltage protection	Vdc	Up to 40 (-40 to +60°C)
Maximum supply current	mA	<25
Reverse polarity protection		Yes
Short circuit protection		
Output to GND		Yes
Output to supply		In 5V regulated mode only
Power-on settlement time	S	<1
Resolution	%	0.025 of measurement range (12 bit)
Non-linearity*	%	<±0.4
Temperature coefficient	ppm/°C	<±30 in 5V supply mode; <±90 in 9-30V supply mode

*Non-linearity is measured using the Least-Squares method on a computerised calibration system

Analog Output (order code A1, A4) – see graph on page 31

Voltage output range		
9-30V supply	Vdc	Absolute voltage, 0.5 to 4.5 (A1) or 0.1 to 4.9 (A4) over measurement range (±3%)
5V supply	Vdc	Ratiometric output voltage - 10 to 90% (A1) or 2 to 98% (A4) of Vs over measurement range (±1%)
Monotonic range	Vdc	0.25 (5%) and 4.75 (95%) nominal (A1)
	Vdc	0.05 (1%) and 4.95 (99%) nominal (A4)
Load resistance	Ω	10k minimum (resistive to GND)
Output noise	mVrms	<1
Input/output delay	mS	<2

PWM Output (order code Pn) – see output characteristics on page 31

PWM frequency	Hz	244 (P1); 500 (P2); or 1000 (P3) ±20% over temperature range
PWM levels	9-30V supply Vdc	0 and 5 nominal (±3%)
	5V supply Vdc	0 and Vs (±1%)
Duty cycle	%	10 to 90 over measurement range
Monotonic range	%	5 and 95 nominal
Load resistance	Ω	10k minimum (resistive to GND)
Rise/fall time	µS	<15

MECHANICAL

Mechanical angle	°	360, continuous
Operating torque	g-cm	10
Maximum rotational speed	°/sec	3600
Weight	g	<30
Mounting		Use 2 x M4 socket head cap screws and M4 washer - maximum tightening torque 2Nm
Phasing		When shaft drive detail is aligned as shown in Electrical Angle Diagram (page 21), output is at mid travel. The sensor housing allows for ±10° adjustment via the mounting flange slots.

TPS280DP

ENVIRONMENTAL

Protection class		IP68 (to 2m depth for 1 hour) and IP69K
Life		60 million operations (30 x 10 ⁶ cycles) of ±75°; Sensing element life is essentially infinite (contactless)
Dither life		Contactless - no degradation due to shaft dither
Operational temperature†	°C	-40 to +140 (5V supply) and +170°C for 72 hours -40 to +135.7 (9V supply option) Derate upper temperature limit by 1.7°C for every 1V increase in supply; e.g. -40 to +100 @30V
Storage temperature	°C	-55 to +140
Vibration		BS EN 60068-2-64:1995 Sec 8.4 (31.4gn rms) 20 to 2000Hz Random
Shock		3m drop onto concrete and 2500g
EMC Immunity level		BS EN 61000-4-3:1999, to 100V/m, 80MHz to 1GHz and 1.4GHz to 2.7GHz (2004/108/EC)

† See Maximum Operating Temperature – Derating graph on page 30.
If the maximum operating temperature is exceeded, the voltage regulator will shut down to protect the device from overheating

OPTIONS

Measurement range (angle)		Select from 20° to 360° in 1° increments (factory programmed) for each output channel
Output		Analog voltage (An) or PWM (Pn)
Output direction		Both clockwise, both anticlockwise or one CW, one ACW
Cable length	m	0.2 or 0.5
Connector		Not fitted (C0) or Mini Sure Seal MSS4R fitted (C1)
OEM options		Outputs can be programmed to provide: non linear laws; switch outputs; clamp voltages; different output phasing CH1/CH2; faster input/output delay; extended analog range; and output mapping for potentiometer replacements.

AVAILABILITY

All standard configurations can be supplied rapidly from the factory – check with your local supplier for more details

ORDERING CODES

			TPS280DP/...../...../...../...../...../.....
Measurement range	CH1 = angle in °	_____	_____
Measurement range	CH2 = angle in °	_____	_____
Output	A1 = Analog 0.5-4.5Vdc A4 = Analog 0.1-4.9Vdc P1 = PWM, 244 Hz P2 = PWM, 500 Hz P3 = PWM, 1000 Hz	_____	_____
Direction	3 = Both clockwise 4 = Both anticlockwise 5 = CH1 CW; CH2 ACW	_____	_____
Cable length	P2 = 0.2m P5 = 0.5m	_____	_____
Connector	C0 = No connector C1 = Mini Sure Seal MSS4R	_____	_____

Accessories (order all items separately)
Mating connector – X61-227-002 Mini Sure Seal MSS4P
X61-227-201 PIN contact (2off required)
X61-227-202 SOCKET contact (2off required)

DIMENSIONS

Note: drawings not to scale

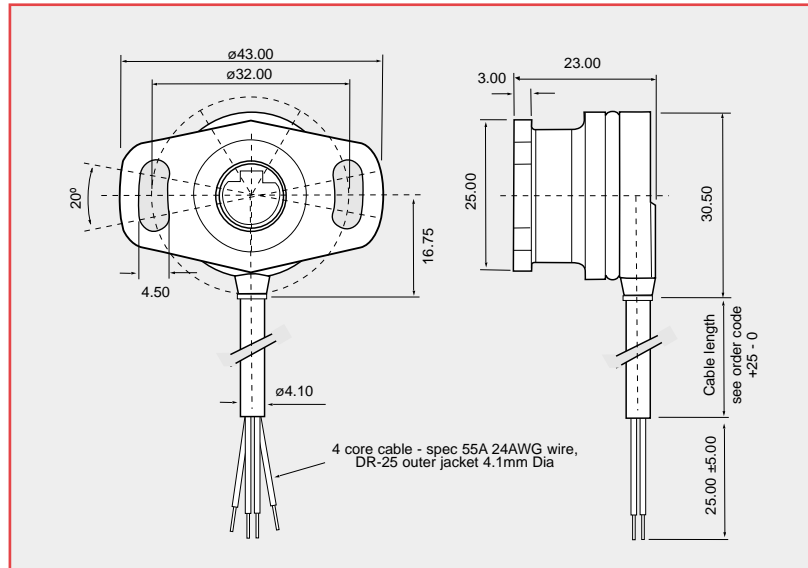

ELECTRICAL ANGLE

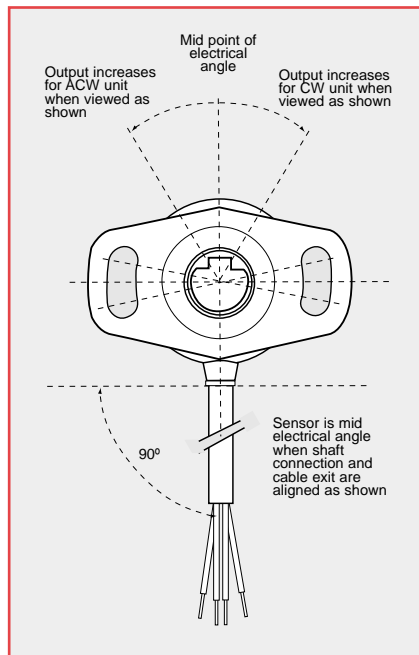

RECOMMENDED MATING DRIVE

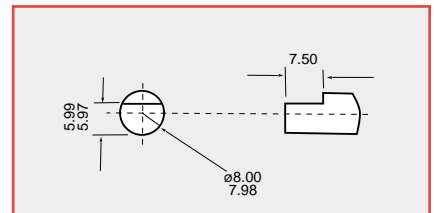

ELECTRICAL CONNECTIONS

Option C0 - 200 or 500mm of 4-core cable: FDR-25 sheathed, with 55A spec (24AWG) cores

Option C1 - Mini sure seal MSS4R fitted to cable

Cable colour	Description
Red	+V Supply
Black	0V Supply GND
Yellow	CH1 Output
White	CH2 Output

Output increases with CW or ACW rotation viewed on shaft drive - depending on selected order code

C1 Connector option

Pin 1 = V+ Supply Pin 3 = CH1 Output
Pin 2 = 0V Supply GND Pin 4 = CH2 Output

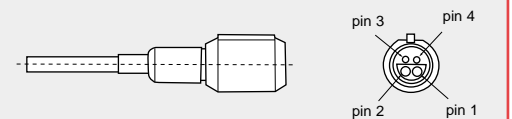

When connecting the sensor, care should be taken with the correct connections. The sensor is provided with reverse polarity protection and short circuit protection between outputs (Yellow & White) to GND (Black), **but if the outputs (Yellow & White) are connected to the supply this will result in device failure.**

SRH501P SINGLE OUTPUT AND SRH502P DUAL OUTPUT

rugged contactless rotary sensors

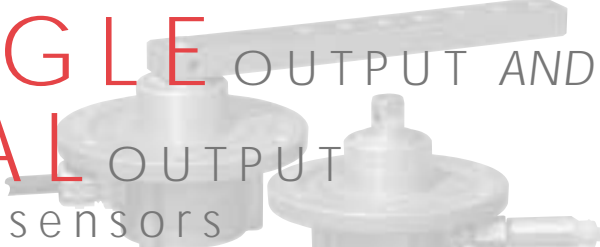

PERFORMANCE

Output options	A1 A4 P1 P2 P3	A2	A3
	0.5-4.5 or 0.1-4.9Vdc PWM	0-10Vdc	4-20mA
ELECTRICAL			
Measurement range	°	20 to 360 in 1° increments	20 to 360 in 1° increments
Supply voltage			
unregulated	Vdc	9 to 30	9 to 30
regulated	Vdc	5 ±0.5	No
Over voltage protection	Vdc	Up to 40 (-40 to +60°C)	Up to 40 (-40 to +60°C)
Maximum supply current	mA	<25	<25+total output current
Reverse polarity protection		Yes	Yes
Short circuit protection			
Output to GND		Yes	Yes
Output to supply		In 5V regulated mode only	Yes
Power-on settlement time	S	< 1	< 1
Resolution	%	0.025 of measurement range (12 bit)	0.025 of measurement range (12 bit)
Non-linearity*	%	< ±0.4	< ±0.4
Temperature coefficient	ppm/°C	< ±30 in 5V supply mode < ±90 in 9-30V supply mode	< ±200 typical < ±200 maximum**

*Non-linearity is measured using the Least-Squares method on a computerised calibration system

**Temperature compensation possible by using graph shown on page 30

Analog Voltage Output - (order code A1, A4) see typical graph on page 31

Voltage output range		
9-30V supply	Vdc	Absolute voltage, 0.5 to 4.5 (A1) or 0.1 to 4.9 (A4) over measurement range (±3%)
5V supply	Vdc	Ratiometric output voltage - 10 to 90% (A1) or 2 to 98% (A4) of Vs over measurement range (±1%)
Monotonic range	Vdc	0.25 (5%) and 4.75 (95%) nominal (A1)
	Vdc	0.05 (1%) and 4.95 (99%) nominal (A4)
Load resistance	Ω	10k minimum (resistive to GND)
Output noise	mVrms	< 1
Input/output delay	mS	< 2

Analog Voltage Output - (order code A2) see typical graph on page 31

Voltage output range	Vdc	Absolute voltage, nominally 0.2 to 9.8 (±0.2V)
Load resistance	Ω	10k minimum (resistive to GND)
Output noise	mVrms	< 1
Input/output delay	mS	3.5

Analog Current Output - (order code A3) see typical graph on page 31

Current output range	mA	Absolute current, nominally 4 to 20 (±2% span)
Load resistance	Ω	400 maximum (resistive to GND)
Output noise	μArms	< 10
Input/output delay	mS	3.75

PWM Output options (order code Pn) see output characteristics on page 31

PWM frequency	Hz	244 (P1); 500 (P2); or 1000 (P3) $\pm 20\%$ over temperature range
PWM levels	9-30V supply Vdc	0 and 5 nominal ($\pm 3\%$)
	5V supply Vdc	0 and Vs ($\pm 1\%$)
Duty cycle	%	10 to 90 over measurement range
Monotonic range	%	5 and 95 nominal
Load resistance	Ω	10k minimum (resistive to GND)
Rise/fall time	μs	<20

MECHANICAL

Mechanical angle	$^\circ$	360, continuous
Operating torque - max	g-cm	1000
Shaft velocity maximum	$^\circ/\text{sec}$	3600
Weight	g	265 (without cable)
Mounting		Use 3 x M6 threaded holes in front face or 3 x M6 (or 1/4 UNC) clearance holes through the flange – See dimensions for details
Phasing		When the shaft flat is facing towards the cable exit, sensor output is at mid electrical angle ($\pm 5^\circ$)

ENVIRONMENTAL

Protection class		IP69K with cable codes Bxx and Sxx IP68 or IP69K with cable code C01 when mating connectors (see page 26) are attached and fully engaged)
Life		20 million operations (10×10^6 cycles) of $\pm 75^\circ$ Sensing element life is essentially infinite (contactless), and the SRH501P/502P life figures refer to the operating shaft seal. Mechanical load (axial and radial) on the shaft should also be considered.
Dither life		Contactless - no degradation due to shaft dither
Shaft side load		2Kg mounted on sensor shaft - tested 3 million cycles
Operational temperature¹	$^\circ\text{C}$	
	Output A1, A4, P1-3	-40 to +140 (5V supply) -40 to +135.7 (9V supply) Derate upper temperature limit by 1.7 $^\circ\text{C}$ for every 1V increase in supply: e.g. -40 to +100 @30V
	Output A2	-40 to +115 (13.5V supply) Derate upper temperature limit by 0.91 $^\circ\text{C}$ for every 1V increase in supply: e.g. -40 to +100 @30V
	Output A3	-40 to +120 (9V supply) Derate upper temperature limit by 1.05 $^\circ\text{C}$ for every 1V increase in supply: e.g. -40 to +98 @30V
Storage temperature	$^\circ\text{C}$	-55 to +140
Vibration		BS EN 60068-2-64:1995 Sec 8.4 (14gn rms) 20 to 2000Hz Random
Shock		3m drop onto concrete and 2500g – all axes
EMC Immunity level		BS EN 61000-4-3:1999, to 100V/m, 80MHz to 1GHz and 1.4GHz to 2.7GHz (35V/m 1.4GHz to 2.7GHz for output A3) (2004/108/EC)
Salt spray		BS EN 60068-2-52: 1996, Test Kb Severity 2 (48hr)
Humidity		BS EN 60068-2-30: 2005, Severity Db (55 $^\circ\text{C}$, 93%RH)

¹ See Maximum Operating Temperature – Derating graphs on page 30.

If the maximum operating temperature is exceeded, the voltage regulator will shut down to protect the device from overheating

OPTIONS

Measurement range (angle)		Select from 20 $^\circ$ to 360 $^\circ$ in 1 $^\circ$ increments (factory programmed) for each output channel
Output		Analog voltage (A1, A2, A4) Analog current (A3) PWM (Pn) CANbus outputs: J1939 (J1); CANopen (O1)
<i>coming soon in 2010</i>		
Output direction		Both clockwise, both anticlockwise or one CW, one ACW
Electrical connections		No cable (A00, S00), 1m, 5m, 10m unscreened (Bxx) or screened (Sxx) cable or M12 receptacle (C01)
Cabled sockets		1.5, 2, 5 & 10m mating cabled sockets can be ordered separately. See details on page 26
Operating levers		Operating levers 155 or 230mm long can be ordered separately. See details on page 25
OEM options		Outputs can be programmed to provide: non linear laws; switch outputs; clamp voltages; different output phasing CH1/CH2; faster input/output delay; extended analog range; and output mapping for potentiometer replacements.

SRH501P AND SRH502P

AVAILABILITY

All standard configurations can be supplied rapidly from the factory – check with your local supplier for more details

ORDERING CODES

NOTE: When selecting output option A3 (4-20mA), cable codes Sxx are the only cable codes allowable.

SINGLE OUTPUT SRH501P

		SRH501P/...../...../...../.....
Measurement range	= angle in °	
Output	A1 = Analog 0.5-4.5Vdc A2 = Analog 0-10Vdc A3 = Analog 4-20mA A4 = Analog 0.1-4.9Vdc P1 = PWM, 244 Hz P2 = PWM, 500 Hz P3 = PWM, 1000 Hz	
Direction	1 = Clockwise 2 = Anticlockwise	
Cable code	A00 = No cable, gland fitting S00 = No cable, screened cable gland (A3 output option – see note) B01 = 1m 3-core unscreened cable, IP69K B05 = 5m 3-core unscreened cable, IP69K B10 = 10m 3-core unscreened cable, IP69K S01 = 1m 3-core screened cable, IP69K (A3 output options – see note) S05 = 5m 3-core screened cable, IP69K S10 = 10m 3-core screened cable, IP69K C01 = M12 screw locking receptacle	

DUAL OUTPUT SRH502P

		SRH502P/...../...../...../...../.....
Measurement range	CH1 = angle in °	
Measurement range	CH2 = angle in °	
Output	A1 = Analog 0.5-4.5Vdc A2 = Analog 0-10Vdc A3 = Analog 4-20mA A4 = Analog 0.1-4.9Vdc P1 = PWM, 244 Hz P2 = PWM, 500 Hz P3 = PWM, 1000 Hz	
Direction	3 = Both clockwise 4 = Both anticlockwise 5 = CH1 CW; CH2 ACW	
Cable code	A00 = No cable, gland fitting S00 = No cable, screened cable gland (A3 output option – see note) B01 = 1m 4-core unscreened cable, IP69K B05 = 5m 4-core unscreened cable, IP69K B10 = 10m 4-core unscreened cable, IP69K S01 = 1m 4-core screened cable, IP69K (A3 output options – see note) S05 = 5m 4-core screened cable, IP69K S10 = 10m 4-core screened cable, IP69K C01 = M12 screw locking receptacle	

Accessories (order separately)
Drive lever kit – SA202195/MK - see page 25
Mating connectors - see details on page 26

DIMENSIONS

Note: drawings not to scale

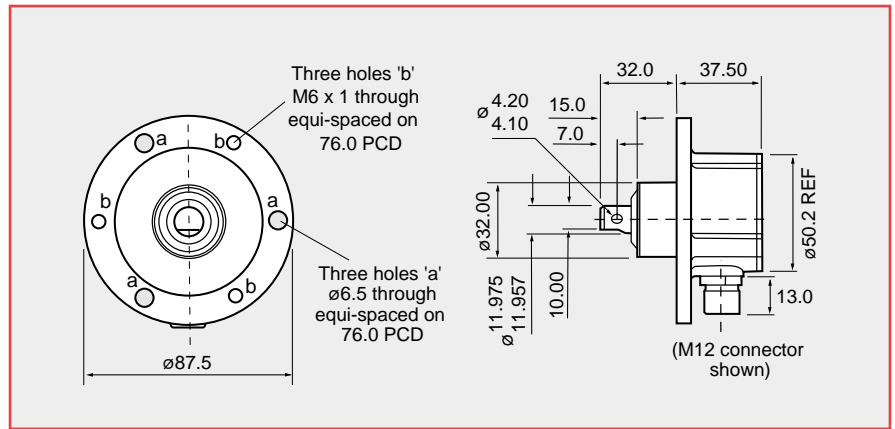

PHASING OF SHAFT TO HOUSING

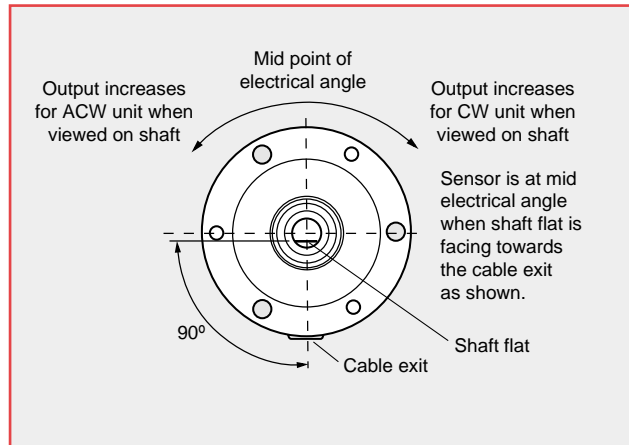

LEVER OPTIONS (order separately)

Lever SA202195/MK1 L = 155
Lever SA202195/MK2 L = 230

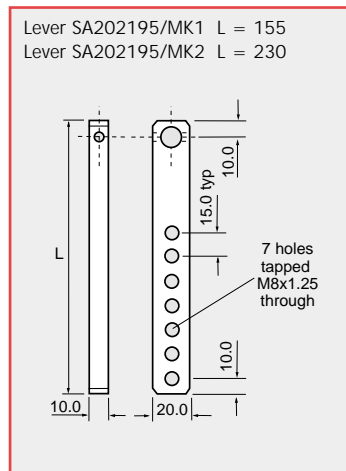

SRH501P AND SRH502P

ELECTRICAL CONNECTIONS

- Option A00** – No cable supplied
- Option S00** – No cable supplied (Fitted gland to suit screened cable)
- Option Bxx** – Cable supplied (1m, 5m or 10m)
- Option Sxx** – Screened cable supplied (1m, 5m or 10m)
- Option C01** – Series M12 screw locking receptacle to IEC 61076-2-101 (Ed.1) / IEC 60947-5-2 fitted to sensor body. Mating cabled sockets to be ordered separately.

CONNECTING CABLE OPTIONS

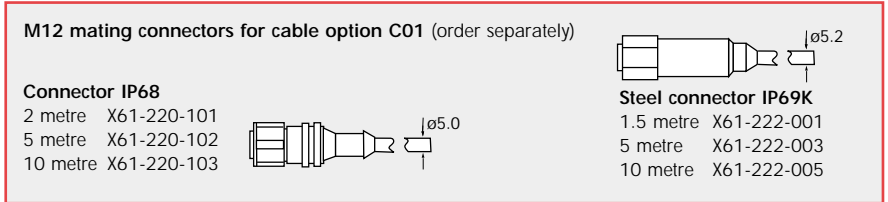
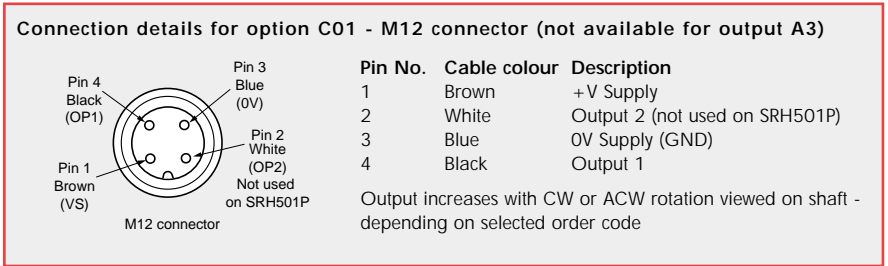
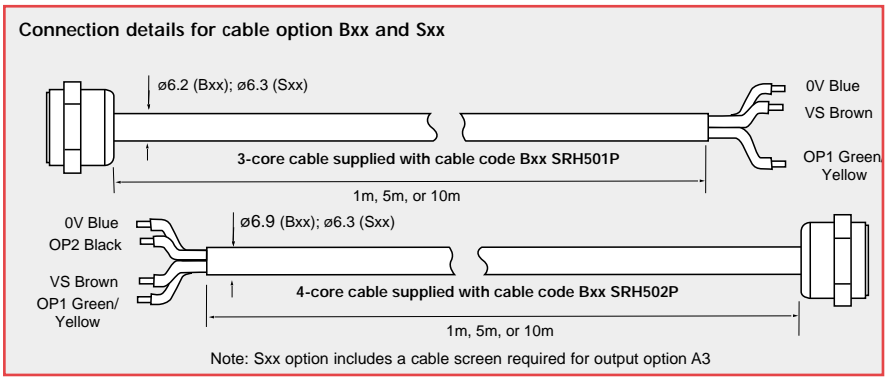
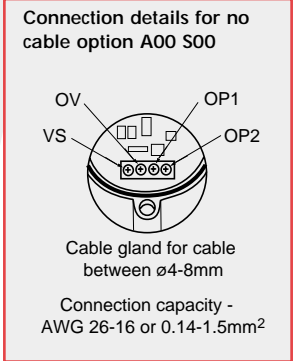

When connecting the sensor, care should be taken with the correct connections. The sensor is provided with indefinite reverse polarity protection and short circuit protection between output to GND, **but if the outputs are connected to the supply this will result in device failure.**

SRH880P SINGLE OUTPUT

rugged contactless rotary sensor

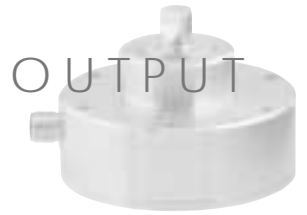

PERFORMANCE

ELECTRICAL

Measurement range	°	20 to 360 in 1° increments
Supply voltage	Vdc	9 to 30 (unregulated) and 5 ±0.5 (regulated)
Over voltage protection	Vdc	Up to 40 (-40 to +60°C)
Maximum supply current	mA	< 12.5
Reverse polarity protection		Yes
Short circuit protection		
output to GND		Yes
output to supply		In 5V regulated mode only
Power-on settlement time	S	< 1
Resolution	%	0.025 of measurement range (12 bit)
Non-linearity*	%	< ±0.4
Temperature coefficient	ppm/°C	< ±50

*Non-linearity is measured using the Least-Squares method on a computerised calibration system

Analog Output (order code A) – see graph on page 31

Voltage output range		
9-30V supply	Vdc	Absolute voltage, 0.5 to 4.5 over measurement range (±3%)
5V supply	Vdc	Ratiometric output voltage - 10 to 90% of Vs over measurement range(±1%)
Monotonic range	Vdc	0.25 (5%) and 4.75 (95%) nominal
Load resistance	Ω	10k minimum (resistive to GND)
Output noise	mVrms	< 1
Input/output delay	mS	< 2

PWM Output (order code P) – See output characteristics on page 31

PWM frequency	Hz	244 ±20% over temperature range
PWM levels	9-30V supply Vdc	0 and 5 nominal (±3%)
	5V supply Vdc	0 and Vs (±1%)
Duty cycle	%	10 to 90 over measurement range
Monotonic range	%	5 and 95 nominal
Load resistance	Ω	10k minimum (resistive to GND)
Rise/fall time	µS	< 20

MECHANICAL

Mechanical angle	°	360, continuous
Operating torque - max	g-cm	1000
Shaft velocity max	°/sec	3600
Weight	g	500
Mounting		Use 3 x M6 threaded holes in front face or 3 x M6 clearance holes through the body - see dimensions for details
Phasing		When the shaft flat is facing the scribed mark on the front face (as shown in the diagram), sensor output is at mid travel (±5°)

SRH880P

ENVIRONMENTAL

Protection class	IP68
Life	20 million operations (10 x 10 ⁶ cycles) of ±75° Sensing element life is essentially infinite (contactless), but the SRH880P life figures refer to the shaft seal. Mechanical load (axial and radial) on the shaft should also be considered.
Dither life	Contactless - no degradation due to shaft dither
Operational temperature†	°C -40 to +120 (5V and 9V supply) -40 to +90 (30V supply)
Storage temperature	°C -55 to +125
Vibration	10 to 2000Hz Random – 12.6gn rms – all axes
Shock	Survival to 2500g – all axes
EMC Immunity level	BS EN 61000-4-3:1999 to 100V/m, 80MHz to 1GHz and 1.4GHz to 2.7GHz (2004/108/EC)

† If the maximum operating temperature is exceeded, the voltage regulator will shut down to protect the device from overheating

OPTIONS

Measurement range (angle)	Select from 20° to 360° in 1° increments (factory programmed) for each output channel
Output	Analog voltage (A) or PWM (Ph)
Output direction	Clockwise or Anticlockwise shaft rotation with increasing output
Cabled socket	2m or 5m cabled socket assemblies available
Body material	Optional anodised aluminium or corrosion resistant stainless steel housing
Operating levers	Operating levers 155 or 230mm long should be ordered separately. See details page 25
OEM options	Outputs can be programmed to provide: non linear laws; switch outputs; clamp voltages; alternative PWM frequencies; faster input/output delay; extended analog range; and output mapping for potentiometer replacements.

AVAILABILITY

All standard configurations can be supplied rapidly from the factory - check with your local supplier for more details

ORDERING CODES

		SRH880P/...../...../...../...../.....
Measuring range	= angle in °	
Output	A = Analog P = PWM	
Direction	1 = Clockwise 2 = Anticlockwise	
Cabled socket	00 = None 02 = 2m 05 = 5m	
Body material	AL = Aluminium SS = Stainless steel	

Accessories (order separately)
Drive lever kit – SA202195/MK - see page 25

DIMENSIONS

Note: drawings not to scale

LEVER OPTIONS

See SRH501P page 25

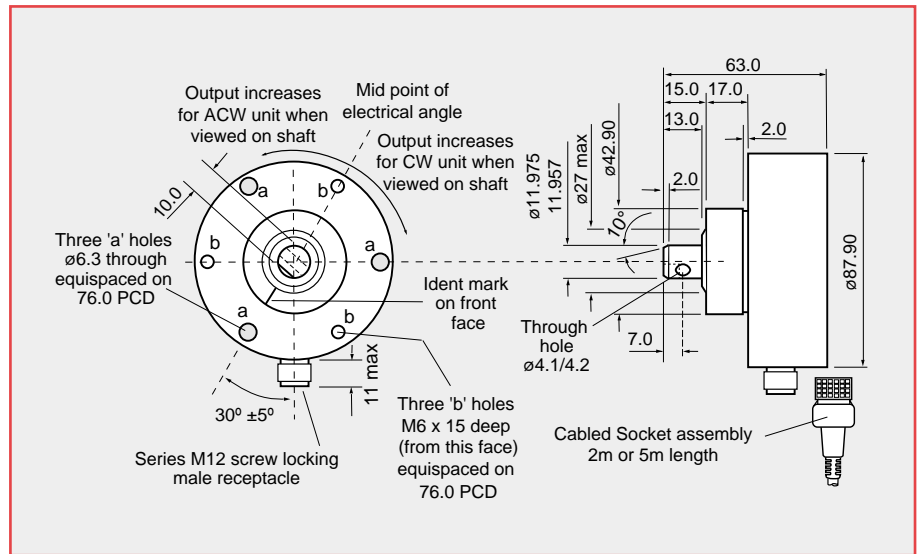

SHAFT FLAT DETAIL

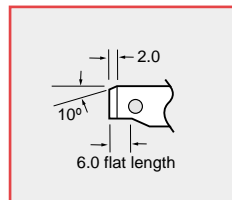

ELECTRICAL CONNECTIONS

Straight cabled socket

E series M12 to IEC 61076-2-101(Ed.1)

/IEC 60947-5-2,

PUR jacket

Conforms to VDE 0472 part 804

Cable temperature range -25 to +90°C

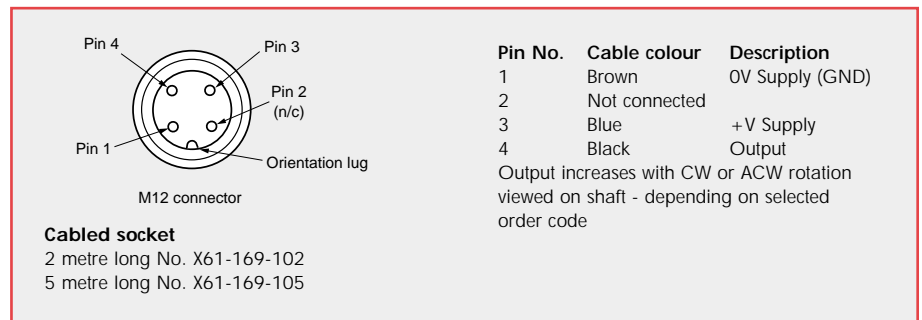

When connecting the sensor, care should be taken with the correct connections.

The sensor is provided with indefinite reverse polarity protection and short circuit protection between output (Pin 4 - Black) to GND (Pin 1 - Brown), **but if the output (Pin 4 - Black) is connected to the supply this will result in device failure.**

TEMPERATURE AND OUTPUT GRAPHS

MAXIMUM OPERATING TEMPERATURE - DERATING GRAPHS

SRH280P

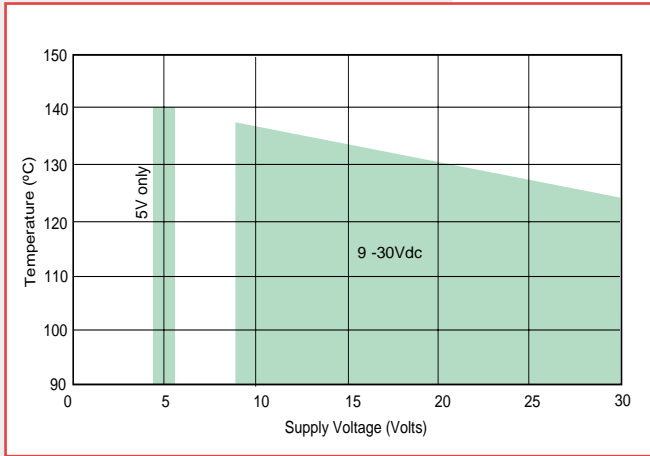

**SRH280DP, NRH280DP, TPS280DP, SRH220DR
SRH501P/502P (not A2 & A3 options)**

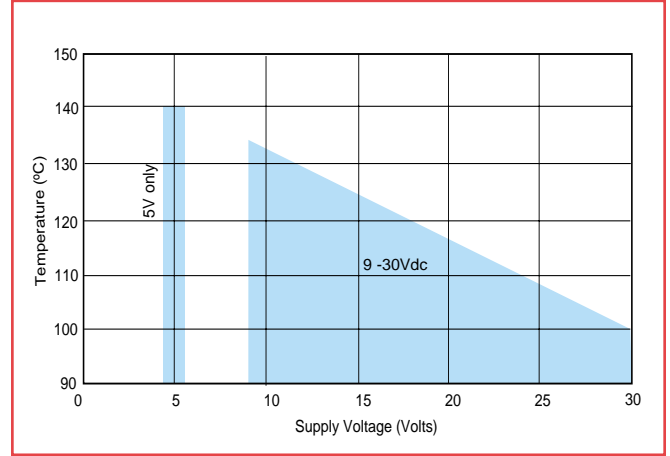

SRH220DR, SRH501P/502P - OUTPUT A2

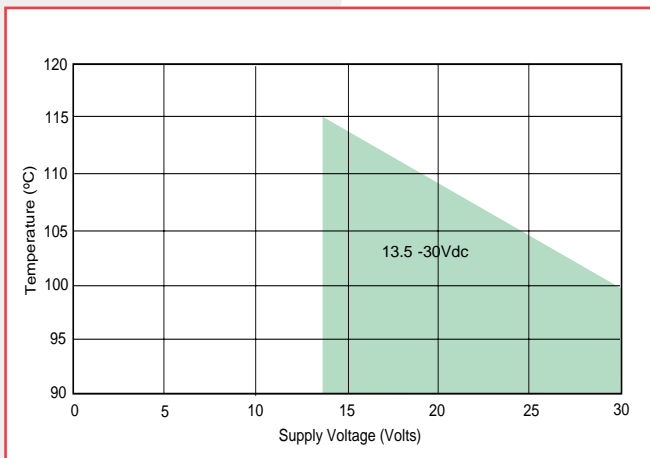

SRH501P/502P - OUTPUT A3

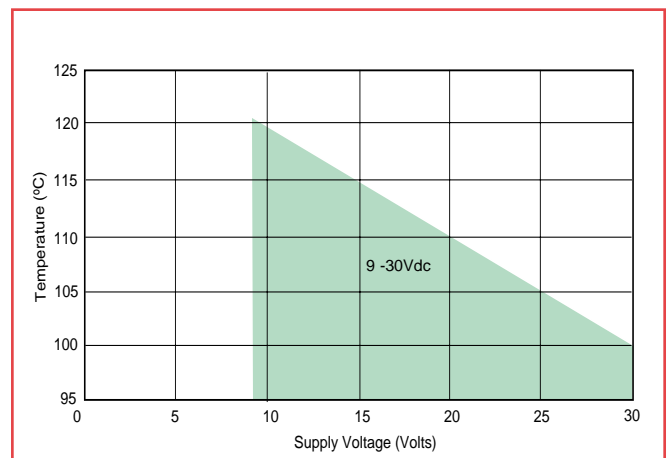

A3 Typical temperature slope characteristic (can be used for compensation)

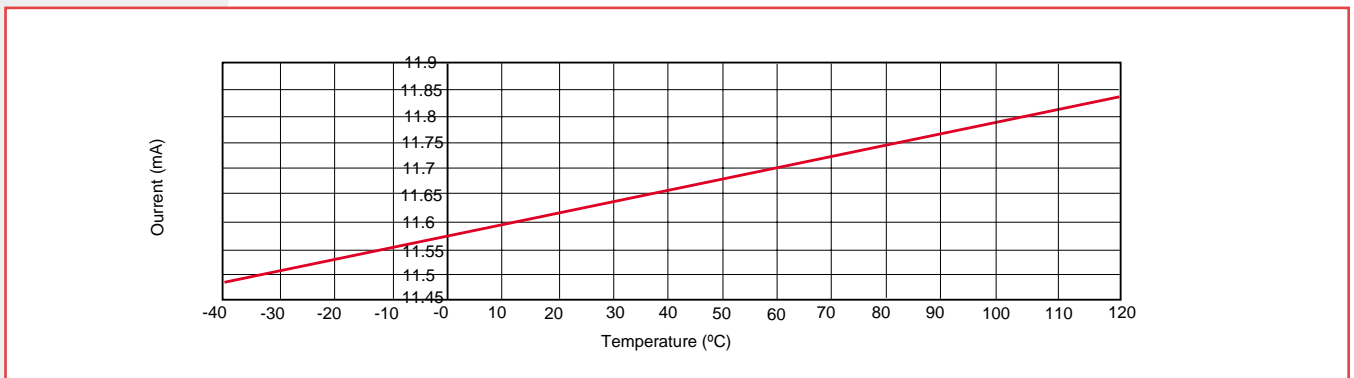

SENSOR OUTPUT GRAPH- examples for three different angles

SRH280P, SRH280DP, NRH280DP, NRH285DR, TPS280DP, SRH220DR - OUTPUT A1 & A6
 SRH501P/502P - OUTPUT A1 & A6
 SRH880P - OUTPUT A

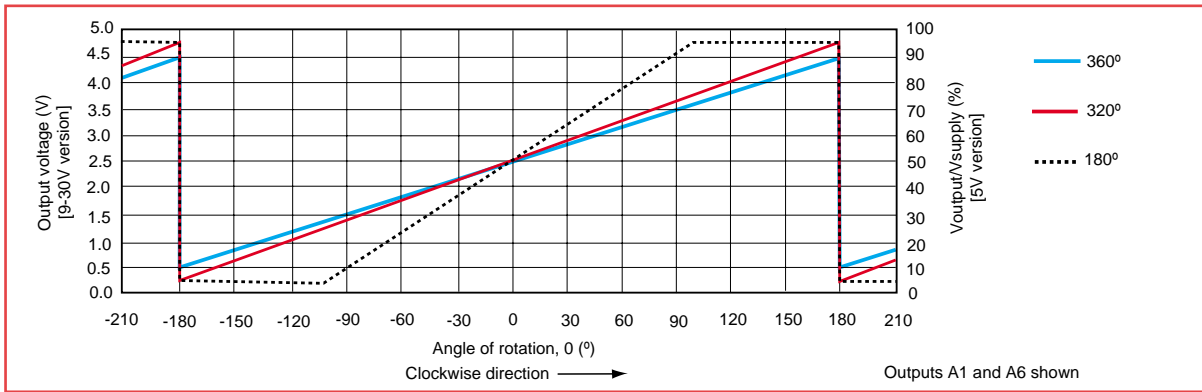

SRH220DR, SRH501P/502P - OUTPUT A2 (0-10Vdc)

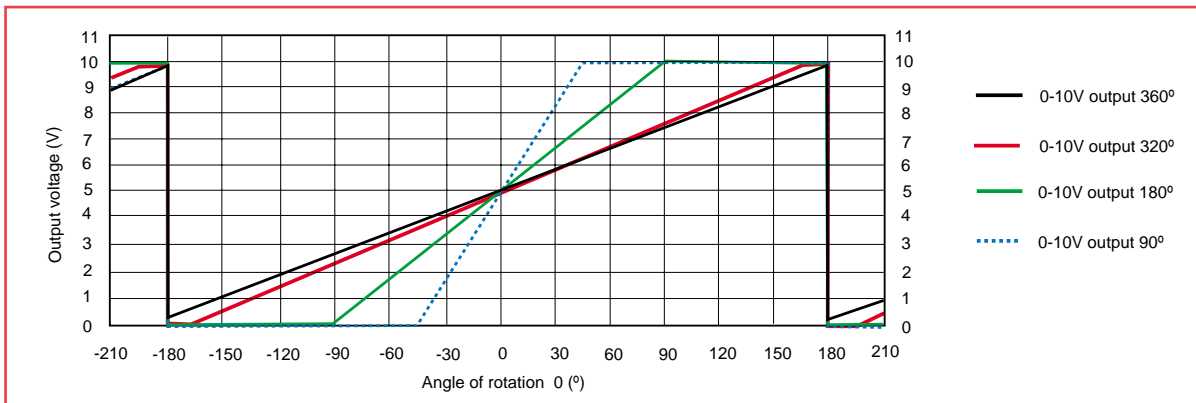

SRH501P/502P - OUTPUT A3 (4-20mA)

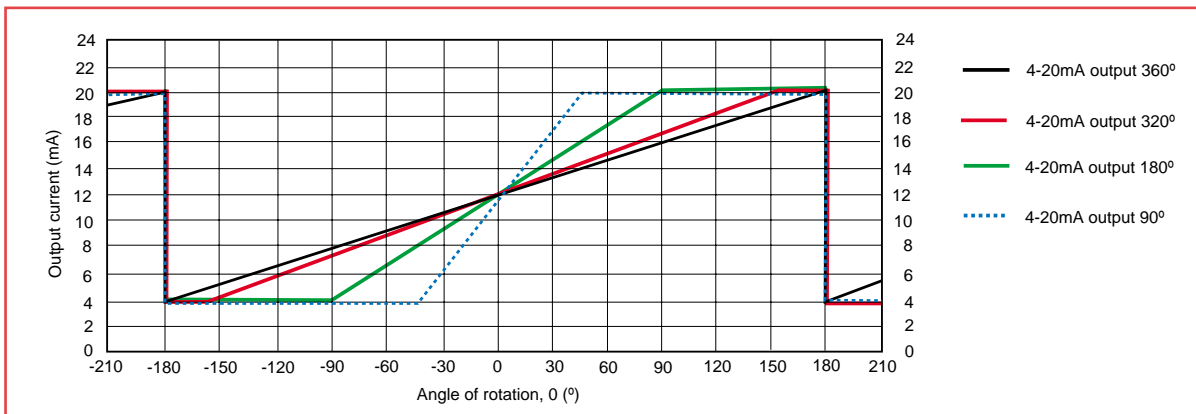

PWM OUTPUT CHARACTERISTICS

SRH280P, SRH280DP, NRH280DP, NRH285DR, TPS280DP, SRH220DR - OUTPUT P1, P2, P3
 SRH501P/502P - OUTPUT P1, P2, P3
 SRH880P - OUTPUT P

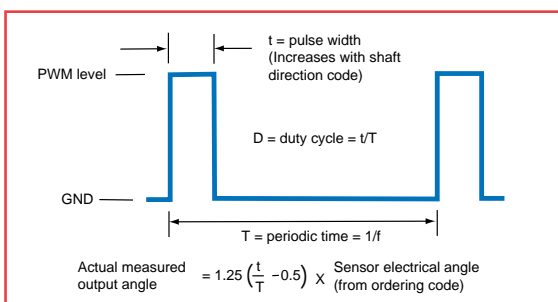

PWM levels = zero volt and 5V ($\pm 3\%$) for 9-30V supply
 = zero volt and V_S ($\pm 1\%$) for 5V supply



www.pennyandgiles.com

Penny & Giles

Position sensors, joysticks and solenoids for commercial and industrial applications.

15 Airfield Road
Christchurch
Dorset BH23 3TG
United Kingdom
+44 (0) 1202 409409
+44 (0) 1202 409475 Fax
sales@pennyandgiles.com

36 Nine Mile Point Industrial Estate
Cwmfelinfach
Gwent NP11 7HZ
United Kingdom
+44 (0) 1495 202000
+44 (0) 1495 202006 Fax
sales@pennyandgiles.com

665 North Baldwin Park Boulevard
City of Industry, CA 91746
USA
+1 626 480 2150
+1 626 369 6318 Fax
us.sales@pennyandgiles.com

Straussenlettenstr. 7b
85053 Ingolstadt,
Germany
+49 (0) 841 61000
+49 (0) 841 61300 Fax
info@penny-giles.de

3-1-A, Xiandai Square,
No 333 Xingpu Rd,
Suzhou Industrial Park, 215126
China
+86 512 6287 3380
+86 512 6287 3390 Fax
sales@pennyandgiles.com.cn

The information contained in this brochure on product applications should be used by customers for guidance only. Penny+Giles Controls Ltd makes no warranty or representation in respect of product fitness or suitability for any particular design application, environment, or otherwise, except as may subsequently be agreed in a contract for the sale and purchase of products. Customer's should therefore satisfy themselves of the actual performance requirements and subsequently the products suitability for any particular design application and the environment in which the product is to be used.

Continual research and development may require change to products and specification without prior notification. All trademarks acknowledged.

© Penny+Giles Controls Ltd 2010

Innovation In Motion

